

AGP[®]

Auto-Reverse Tapping Magnetic Core Drill

TP2000



Instruction Manual
CE CB



TECHNICAL DATA

Power input	1100 W
Voltage	220-240 V~ 50-60 Hz, or 110-120 V~ 50-60 Hz (See Machine Nameplate)
Drilling Mode: No / Full Load min ⁻¹	550 / 330
Tapping Mode: No / Full Load min ⁻¹	150 / 90
Spindle Coupling	31 mm (Bilz no.2 type)
Annular Cutter Arbor	Set Screw Type, 19 mm Weldon Shank
Annular Cutters	Ø 35 mm x 50 mm (1-3/8" x 2")
Taps	20 mm (13/16")
Twist Drills	13 mm (1/2") Shank
Total Stroke	150 mm (6")
Magnetic Adhesion	15,000 N (3,372 lb-f)
Net Weight	14.5 kg (32.0 lb)

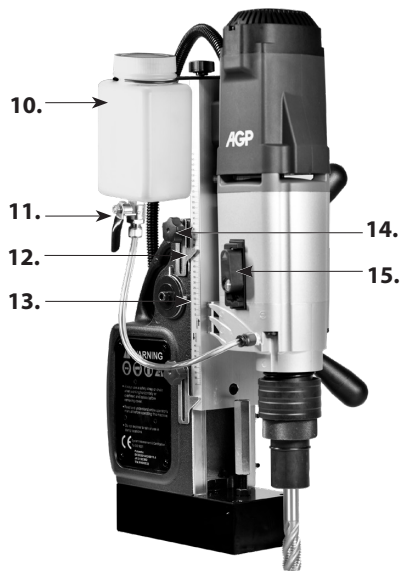
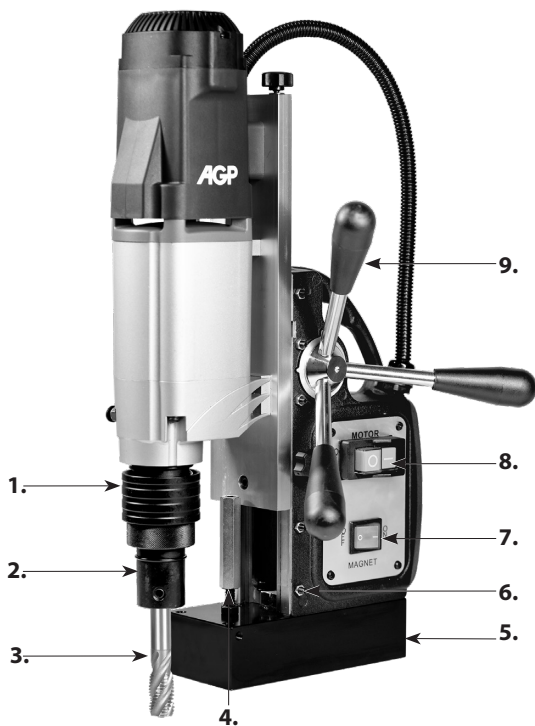

- 1. Quick release collar
- 2. Universal Tap Chuck
- 3. Tap (not included)
- 4. Travel limiter stop
- 5. Magnet Base
- 6. Gib adjustor screw
- 7. Magnet switch
- 8. Motor switch

- 9. Crank handle
- 10. Coolant tank
- 11. Coolant feed tap
- 12. Adjustable Pointer
- 13. Depth Meter Scale
- 14. Lock Knob
- 15. Mode selector*

* **Mode selector** (for shifting to Auto-reverse tapping mode or standard drilling mode)

GENERAL SAFETY INSTRUCTIONS



WARNING! Read all safety warnings and all instructions. Failure to follow the warnings and instructions may result in electric shock, fire and/or serious injury.

Save all warnings and instructions for future reference. The term “power tool” in the warnings refers to your mains operated (corded) power tool or battery-operated (cordless) power tool.

1) WORK AREA SAFETY

- a. **Keep work area clean and well lit.** Cluttered or dark areas invite accidents.
- b. **Do not operate power tools in explosive atmospheres, such as in the presence of flammable liquids, gases or dust.** Power tools create sparks which may ignite the dust or fumes.
- c. **Keep children and bystanders away while operating a power tool.** Distractions can cause you to lose control.
- d. **Never leave the electric power tool unattended.** Only leave the machine when the tool in use has come to a complete standstill.

2) ELECTRICAL SAFETY

- a. **Power tool plugs must match the outlet. Never modify the plug in any way. Do not use any adapter plugs with earthed (grounded) power tools.**

Unmodified plugs and matching outlets will reduce risk of electric shock.

- b. **Avoid body contact with earthed or grounded surfaces such as pipes, radiators, ranges and refrigerators.** There is an increased risk of electric shock if your body is earthed or grounded.
- c. **Do not expose power tools to rain or wet conditions.** Water entering a power tool will increase the risk of electric shock.
- d. **Do not abuse the cord. Never use the cord for carrying, pulling or unplugging the power tool. Keep cord away from heat, oil, sharp edges or moving parts.** Damaged or entangled cords increase the risk of electric shock.
- e. **When operating a power tool outdoors, use an extension cord suitable for outdoor use.** Use of a cord suitable for outdoor use reduces the risk of electric shock.
- f. **If operating a power tool in a damp location is unavoidable, use an earth leakage circuit breaker.** Use of an earth leakage circuit breaker reduces the risk of electric shock.

3) PERSONAL SAFETY

- a. **a) Stay alert, watch what you are doing and use common sense when operating a power tool. Do not use a power tool while you are tired or under the influence of drugs, alcohol or medication.** A moment of inattention while operating power tools may result in serious personal injury.
- b. **b) Use personal protective equipment. Always wear eye protection.** Protective equipment such as dust mask, non-skid safety shoes, hard hat, or hearing protection used for appropriate conditions will reduce personal injuries.
- c. **Prevent unintentional starting. Ensure the switch is in the off-position before connecting to power**

source and/or battery pack, picking up or carrying the tool. Carrying power tools with your finger on the switch or energising power tools that have the switch on invites accidents.

- d. Remove any adjusting key or wrench before turning the power tool on.** A wrench or a key left attached to a rotating part of the power tool may result in personal injury.
- e. Do not overreach. Keep proper footing and balance at all times.** This enables better control of the power tool in unexpected situations.
- f. Dress properly. Do not wear loose clothing or jewelry. Keep your hair, clothing and gloves away from moving parts.** Loose clothes, jewelry or long hair can be caught in moving parts.
- g. If devices are provided for the connection of dust extraction and collection facilities, ensure these are connected and properly used.** Use of dust collection can reduce dust-related hazards.
- h. Do not let familiarity gained from frequent use of tools allow you to become complacent and ignore tool safety principles.** A careless action can cause severe injury within a fraction of a second.

4) POWER TOOL USE AND CARE

- a. Do not force the power tool. Use the correct power tool for your application.** The correct power tool will do the job better and safer at the rate for which it was designed.
- b. Do not use the power tool if the switch does not turn it on and off.** Any power tool that cannot be controlled with the switch is dangerous and must be repaired.
- c. Disconnect the plug from the power source and/or the battery pack from the power tool before making any adjustments, changing accessories, or storing power tools.** Such preventive safety measures reduce the risk of starting the power tool accidentally.
- d. Store idle power tools out of the reach of children and do not allow persons unfamiliar with the power tool or these instructions to operate the power tool.** Power tools are dangerous in the hands of untrained users.
- e. Maintain power tools. Check for misalignment or binding of moving parts, breakage of parts and any other condition that may affect the power tool's operation. If damaged, have the power tool repaired before use.** Many accidents are caused by poorly maintained power tools.
- f. Keep cutting tools sharp and clean.** Properly maintained cutting tools with sharp cutting edges are less likely to bind and are easier to control.
- g. Use the power tool, accessories and tool bits etc., in accordance with these instructions, taking into account the working conditions and the work to be performed.** Use of the power tool for operations different from those intended could result in a hazardous situation.
- h. Keep handles and grasping surfaces dry, clean and free from oil and grease.** Slippery handles and grasping surfaces do not allow for safe handling and control of the tool in unexpected situations.

5) SERVICE

Have your power tool serviced by a qualified repair person using only identical replacement parts. This will ensure that the safety of the power tool is maintained.

SYMBOLS USED IN THIS MANUAL

V.....volts

A.....amperes

Hz.....hertz

W.....watt

~.....alternating current

n_0no load speed

min^{-1}revolutions or reciprocation
per minute



.....warning of general danger



.....with electrical earth



.....read these instructions



.....always wear eye protection



.....always wear a dust mask.



.....always wear hearing protection



.....wear safety-approved hard hat



.....Keep hands clear – pinching hazard.



DANGER! Keep hands away from cutting area and the blade.



Rotating parts - entanglement hazard. Keep hands, loose clothing and long hair away from moving parts



Do not dispose of electric tools, accessories and packaging together with household waste material

TERMINOLOGY USED IN THE MANUAL

1. **Warning:** This term means that there is a risk of physical harm or death to the operator or people nearby.
2. **Caution:** This term means that there is a risk of damage to the machine, cutting tool or other equipment
3. **Note:** This terms offers useful information relating to the operation of the machine or its maintenance.

SPECIFIC SAFETY RULES

Magnetic mounting can release, so always use a Safety Strap.

1. **The magnet's adhesion depends on the thickness of the work piece.** Always ensure that the work piece is a minimum of 12mm (7/16 in.) thick. If it is not, then use a piece of steel plate at least 12mm thick and larger than the magnet below the workpiece to supplement the magnetic adhesion.
2. **Metal chips and other debris will seriously hamper magnetic adhesion.** Always ensure that the magnet is clean.
3. **Other units used on the same receptacle will cause uneven voltage which could lead to the magnet releasing.** Always use the tool alone on the receptacle.
4. **It is hazardous to use the drill upside-down.** Do not exceed 90 degrees from horizontal.

5. **Avoid the magnet releasing.** Ensure that the magnet has properly adhered to the work piece before beginning drilling.
6. **Avoid operating annular cutters without coolant fluid.** Always check coolant level before operating.
7. **Do not operate with dull or damaged cutting tools.** This may overload the motor.
8. **Protect the motor.** Never allow coolant fluid, water, or other contaminants to enter the motor.
9. **Metal chips are often very sharp and hot.** Never touch them with bare hands. Clean up with a magnetic chip collector and a chip hook or other appropriate tool.

CAUTION: NEVER position machine on a workpiece between the electrode and the ground of any arc type welder. Damage to the machine will result as the welder will ground through the machine's ground cable.

WARNING: NEVER attempt to use machine with incorrect current or abnormally low voltage. Check machine nameplate to ensure that correct voltage and Hz are used.

ASSEMBLY

COOLANT TANK assembly required. First attach clear tube to the bottom of the coolant tank. To do this, first loosen the nut and slide nut onto the tube. Then slide tube onto the nipple. Then tighten the nut.

Slide tank hanger over the screw on the upper right hand side of slide and tighten.

Finally insert the other end of the tube into the quick-release connector in the gearbox. Just directly push in to install. (To remove, first firmly push the red collar of the connector and pull the tube out.)

Cutting coolant fluid is always required when using annular cutters. Open tank cover and fill. Check coolant fluid level often. Keep coolant tap closed when not in use.

Chip guard must be used. To attach the chip guard, use the supplied butterfly bolts to bolt to the magnet. It is not necessary to remove guard to clean chips. Simply raise guard to its upper position.

Safety Strap must be used. Loop strap around the workpiece, feed strap through the power tool's handle, and tighten strap using the ratchet mechanism.

SPECIAL INSTRUCTIONS FOR AUTO-REVERSE TAPPING

THIS MACHINE IS THE FIRST OF ITS KIND SO SPECIAL CARE MUST BE PAID TO THE OPERATING INSTRUCTIONS BELOW TO UNDERSTAND ITS TAPPING FUNCTION. CAUTION: Before beginning tapping ensure that the hole is the correct size for the tap. An undersize hole will cause the tap to jam causing a hazardous situation.

CAUTION: When tapping a blind hole always correctly use the travel limiter stop to ensure that there is enough clearance so that you do not bottom-out the tap. Bottoming will cause the tap to jam, causing a hazardous situation.

CAUTION: Never attempt to tap with the gearbox selector in standard drilling mode. The much higher speed of the standard drilling mode will damage the tap and cause a hazardous situation .

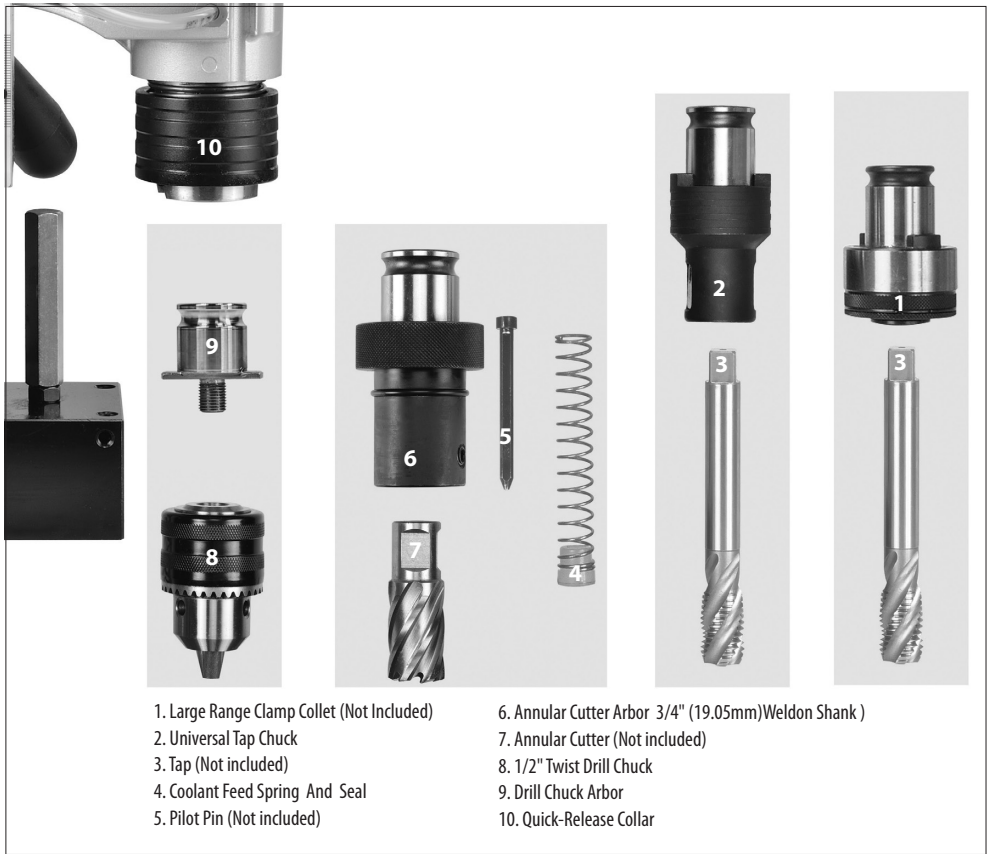

COOLING: The automatic through-the-spindle cooling function is only effective when using annular cutters. When tapping or using twist drills, cutting oil must be added manually.

SETTING UP FOR TAPPING

CAUTION: Never use a cutting tool which is larger than the maximum rated capacity of the machine.

CAUTION: Always follow the tap manufacturer's recommendation for selecting the correct size hole for tapping.

CAUTION: Never attempt to change gears on a running machine! Only change gears when the machine is at rest.

1. For tapping, select the universal tap chuck. or, if you are using an outside sourced tap collet or quick

change adapter, you may mount it directly into the machine's coupling. If there is already another arbor in the machine, simply push up on the Quick-Release Collar and remove.

2. To insert the universal tap chuck or accessory, push up on the Quick-Release Collar and insert the shank into the coupling. Turn until the tangs line up and the Collar is able to close. Ensure that it is securely in place.
3. Using the universal tap chuck, use the key to turn it to open its jaws enough to fit the square of the tap. Ensure that the corners of the square are properly located in the jaws. Then use the key to securely tighten the chuck.



NOTE: Make sure that the tap is inserted as deeply as possible into the jaws. An improperly seated tap will run off center and could result in damage to the jaws or tap.

4. If it is in drilling mode, shift the gearbox to tapping mode by swinging the gear selector tab out of the detent slot then shifting downwards into tapping mode. Then pop the selector tab back into the detent. It will sometimes be necessary to turn the spindle by hand a little to get it to shift all the way.

Only grab the arbor when turning the spindle, never the quick-release collar. Otherwise, it will be easy to accidentally release the arbor and it will fall out. Follow the "TAP" symbol on the gear case. (The small arrow on the tab will be pointing upwards when it is shifted correctly).

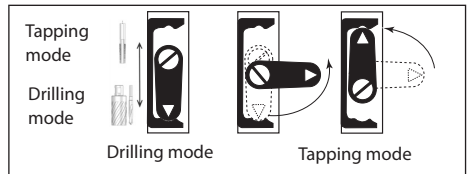
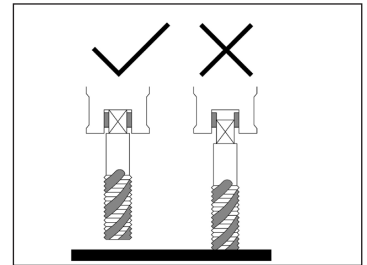

SETTING THE DEPTH METER

THE PROPER USE OF THE TAPPING DEPTH METER

Whenever tapping blind holes, the Tapping Depth Meter in conjunction with the Travel Limiter Stop must be used for ensuring the prevention of possible damage to the gearbox and the tap.

ALWAYS ENSURE THAT THE HOLE ISN'T OVER TAPPED. THE HOLE'S DEPTH MUST BE LONGER THAN THE NEEDED THREADING DEPTH!!

1. Pre-place the tap against the work piece. To zero-in the needle.
2. While keeping the tap against the workpiece, adjust the pointer to the 4mm datum position on the left-

hand tapping scale. (The tapping function has an extra 4mm movement when the crank handle is released, a 4mm pre-adjustment has been made on the scale. Therefore, when "zeroing-in" the tapping scale, the 4mm mark is the effective datum point. A minimum depth of 5mm can be tapped and a maximum of 40mm). Now that you have the depth scale calibrated, you may use the meter reading to set the Travel Limiter Stop.

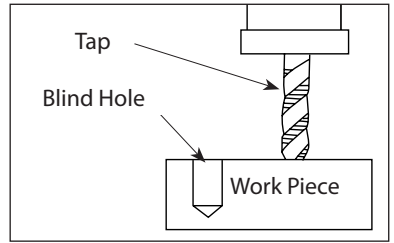

SETTING THE TRAVEL LIMITER STOP

When at its lowest position, the travel limiter stop will not effect the stroke of the slide. When tapping blind holes the travel limiter stop must be used to avoid the tap bottoming. When tapping through holes or when drilling, the limiter stop is not needed.

To properly set

1. With the tap mounted on the machine, place the machine on the workpiece.
2. Using the depth meter, Carefully measure the furthest depth that the tap is intended to go. With the tap overhanging the edge of the workpiece, lower the slide to the intended depth.
3. Loosen the lock nut then adjust the stop to just meet the slide, retighten the lock nut.
4. When no longer needed, lower the stop to its lowest position.

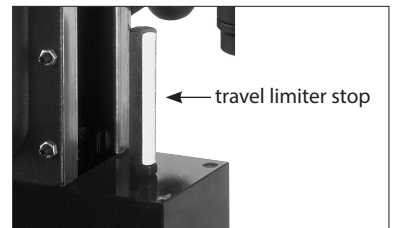
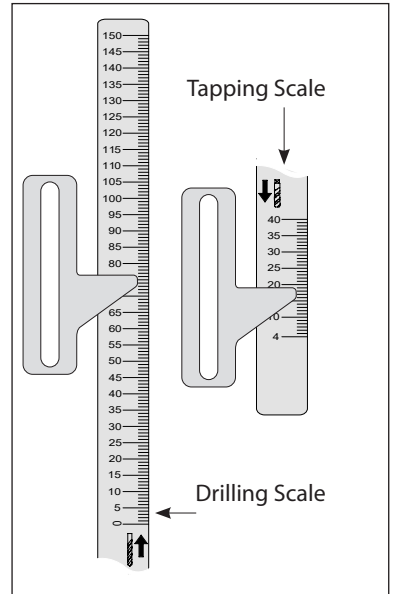

TAPPING OPERATION

NOTE: It is recommended to always use cutting oil on the tap to give longer tap life and better results. The automatic coolant system only works for annular cutters. Taps must be lubricated manually.

1. Before tapping begins, there must be a proper sized hole. Make sure that the hole is the correct size for the tap.
2. With the magnet switch still off, maneuver the tap and machine to ensure that the tap is perfectly aligned with the hole. Actually insert the nose of the tap into the hole slightly to ensure perfect alignment, then switch on the magnet.

3. If you are tapping a blind hole, please use the Travel Limiter Stop and the tapping depth meter see "THE PROPER USE OF THE TAPPING DEPTH METER" and "SETTING THE TRAVEL LIMITER STOP" above.
4. To begin tapping, start the machine by turning on the motor switch and use the crank to feed the tap to the work. When there is no feed pressure from the crank, the spindle will be in neutral and will not spin. When there is forward feed pressure, the spindle will automatically spin in the forward (right hand) direction. Tap the hole, then simply back out the crank to reverse the spindle and remove the tap. When there is backward pressure from the crank, the spindle will automatically spin in the reverse (left hand) direction. (Note that it is not possible to tap left-hand threads with this machine).



CAUTION: Do not too much reverse pressure when backing out the tap or the tap could pull out of the chuck. This could lead to premature wear of the chuck.

SETTING UP FOR TWIST DRILLING

CAUTION: Never use a cutting tool which is larger than the maximum rated capacity of the machine.

NOTE: It is recommended to always use cutting oil on the twist drill to give longer drill life and better results. The automatic coolant system only works for annular cutters. Twist drills must be lubricated manually

1. If it is not mounted, mount the chuck to the Drill Chuck Arbor.
2. Push up on the Quick-Release Collar to mount the Drill Chuck Arbor to the machine. Double check to ensure that the arbor is locked in place.
3. Insert the drill bit into the chuck and tighten with the chuck key.
4. If it is in tapping mode, shift the gearbox to drilling mode by swinging the gear selector tab out of the detent slot then shifting upwards into drilling mode. Then pop the selector tab back into the detent. It will usually be necessary to grab the arbor and push the spindle upwards while turning a little by hand to get the selector to shift all the way up. Only grab the Arbor when turning the spindle, never the Quick-Release Collar. Otherwise, it will be easy to accidentally release the arbor and it will fall out. Follow the Twist drill & annular cutter" symbol on

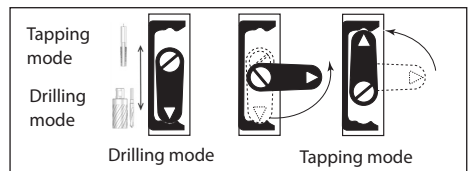

the gear case. (The small arrow on the tab will be pointing downwards when it is shifted correctly).

5. Proceed to drill as described below titled: "OPERATION-GENERAL (Annular cutters & twist drills only)".

SETTING UP FOR ANNULAR CUTTERS

1. If another arbor or accessory is in place, remove it from the machine.
2. Insert the Coolant Feed Spring with the Seal facing downwards into the shaft of the Annular Cutter Arbor.
3. Mount the Annular Cutter Arbor into the machine by pressing up on the Quick Release Collar and turning the arbor until the collar snaps closed. Once it is closed, tighten the Knurled Lock Ring by turning clockwise by hand.
4. Insert the proper sized pilot pin in the annular cutter. Using the L-hex key, loosen the 2 set screws to allow the mounting of the annular cutter. Ensure that the flat of the cutter shank is facing the set screw and then tighten.
5. If it is in tapping mode, shift the gearbox to drilling mode by swinging the gear selector tab out of the detent slot then shifting upwards into drilling mode. Then pop the selector tab back into the detent. It will usually be necessary to grab the arbor and push the spindle upwards while turning a little by hand to get the selector to shift all the way up. Only grab the Arbor when turning the spindle, never the Quick-Release Collar. Otherwise, it will be easy to accidentally release the arbor and it will fall out. Follow the "Twist drill & annular cutter" symbol on the gear case. (The small arrow on the tab will be pointing downwards when it is shifted correctly).

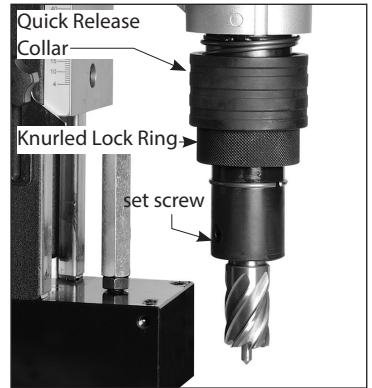

Shifting into drilling mode

Push UP on the spindle while shifting from Tapping Mode to Drilling Mode

6. Proceed to drill as described below titled: "OPERATION-GENERAL (Annular cutters & twist drills only)"

OPERATION-GENERAL (Annular cutters & twist drills only)

WARNING: Always ensure that the magnet is adhered properly to the work piece before beginning drilling.

NOTE: If mounting to a curved surface beam, mount the machine parallel to the curve in the work piece.

WARNING: Avoid operating at more than a 90 degrees from horizontal. When drilling at such an angle

take precautions to prevent cutting coolant from entering the motor. Paste-type coolant should be used.

1. First fit tool into arbor and line up with intended center of cut. Then switch magnet on.
2. Press green motor on button to start motor. Use the crank handle to feed to work. Always use very light pressure when beginning the cut and just as the tool is breaking through. The crank handle offers tremendous leverage, so do not use too much force. Allow the cutting tool to determine the pace. With experience, the operator will be able to determine the best pace to feed the tool to the work. There should be some degree of audible slowing of the motor but not bogging in the cut. Correct cutting speed with a properly sharp annular cutter will produce long unbroken chips which produce a "bird's nest" shaped bundle of chips around the cut.

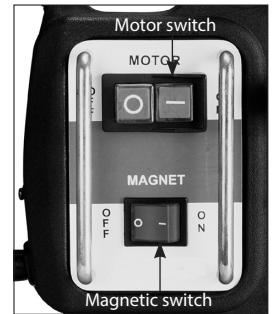

NOTE: Always ensure that the cutting tool is sharp. A dull cutter typically will have finer and/or choppy shavings.

WARNING: ALWAYS clear chips when there is too much build-up. Excessive chip build-up could result in a jammed cutter or other hazardous situations.

WARNING: The slug ejected at end of cut is very hot. Always provide a method of catching the slug, as the ejected slug may cause injury to people below.

NOTE: Lock the slide lock on the side of the machine in the fully raised position when at rest to prevent the slide from accidentally slamming down. Remember to unlock it again before commencing drilling.

CAUTION: Never attempt to cut half-circles or to stitch drill (drill overlapping holes) with a TCT cutter. This may destroy the cutter.

CAUTION: Never attempt to reenter a half-finished cut if the magnet has been turned off and the machine has been shifted in the interim. This may destroy the cutter.

MAINTENANCE

Every 50 hours of operation blow compressed air through the motor while running at no load to clean out accumulated dust. (If operating in especially dusty conditions, perform this operation more often.)

Keep the machine clean and free of chips. Check for loose fittings and tighten as needed.

Ensure that the ventilation slots are clear so that motor can be cooled normally. Blow low pressure compressed air through the ventilation slots with the motor running to keep motor clean.

THE GIBS (DOVETAIL SLIDES)

The gibs require adjustment if too loose. To adjust, loosen the lock nuts and adjust the adjustor screws evenly while moving the handle up and down. Adjust so that there is no free play, and no binding anywhere in its range of travel. Then retighten the lock nuts. Periodically check, lubricate, and adjust as needed.

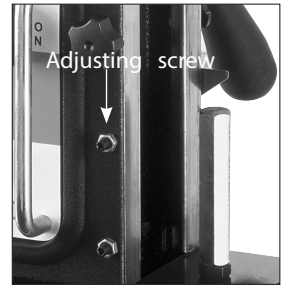

THE CARBON BRUSHES

The carbon brushes are a normal wearing part and must be replaced when they reach their wear limit.

Caution: Always replace the brushes as a pair.

To replace:

1. Remove the 4 screws and remove the motor tail cover.
2. Using pliers rotate the brush spring out of the way and slide the old carbon brush out of the brush holder.
3. Unscrew the screw to remove the brush lead. The old carbon brush may now be lifted away.
4. Install a new brush. Installation is the reverse of removal.
5. Replace the motor tail cover.

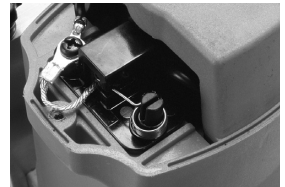

AUTO STOP CARBON BRUSH

Due to the auto stop carbon brush design, if the machine comes to a stop without any reason, the brushes have to be checked. The auto stop feature stops the machine before the carbon brushes are finished and protects the motor.

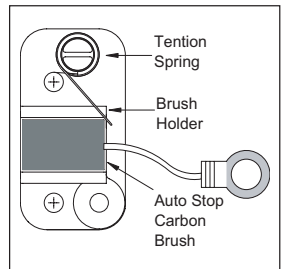

MAGNET TROUBLESHOOTING

Full magnet performance is absolutely essential for magnetic drill operation.

If the magnet works, but does not hold well, it is likely that one of the coils has failed. If the magnet does not work at all, it is likely to be a failed rectifier. (It is highly unlikely that both magnet coils would fail at the same time)

NOTE: A faulty magnet coil can also damage the rectifier, so whenever there is a magnet problem, BOTH the magnet coils and rectifier must be checked.

WARNING: Never attempt to operate a magnetic drill with a faulty magnet!

CHECKING THE MAGNET (qualified technicians only)

If the magnet is not working well, it must be checked. Separate the wires of each individual coil and test the resistance of each coil separately. (note that 110V models are wired in parallel and 230V models are wired in series) The resistance of the coils of different sizes of magnets varies, but it should be in the region of hundreds of ohms. Most importantly, both coils must have very nearly the same resistance. If one of the coils has zero resistance, it means that it is shorted. If one of the coils has infinite resistance, it means that the circuit is broken. If either coil has a problem, the magnet must be replaced. A faulty magnet may also cause damage to the rectifier. Also check the rectifier when replacing a faulty magnet. (see below)

CHECKING THE RECTIFIER (Qualified technicians only)

The rectifier takes the AC household current and converts it to DC to power the magnet. If it fails, the magnet coils will not receive power.

Disconnect the rectifier and test the resistance of both circuits of the rectifier between the AC and the DC sides. Note that polarity matters, so you can only take a reading if test probes are oriented correctly. Each side will be the opposite of the other. Both circuits should have very nearly the same resistance reading. If one of the circuits has zero resistance, it means that it is shorted. If one of the circuits has infinite resistance, it means that the circuit is broken.

If the replacement of the power supply cord is necessary, this has to be done by the manufacturer or their agent in order to avoid a safety hazard.

WARNING: All repairs must be entrusted to an authorized service center. Incorrectly performed repairs could lead to injury or death.

WIRING

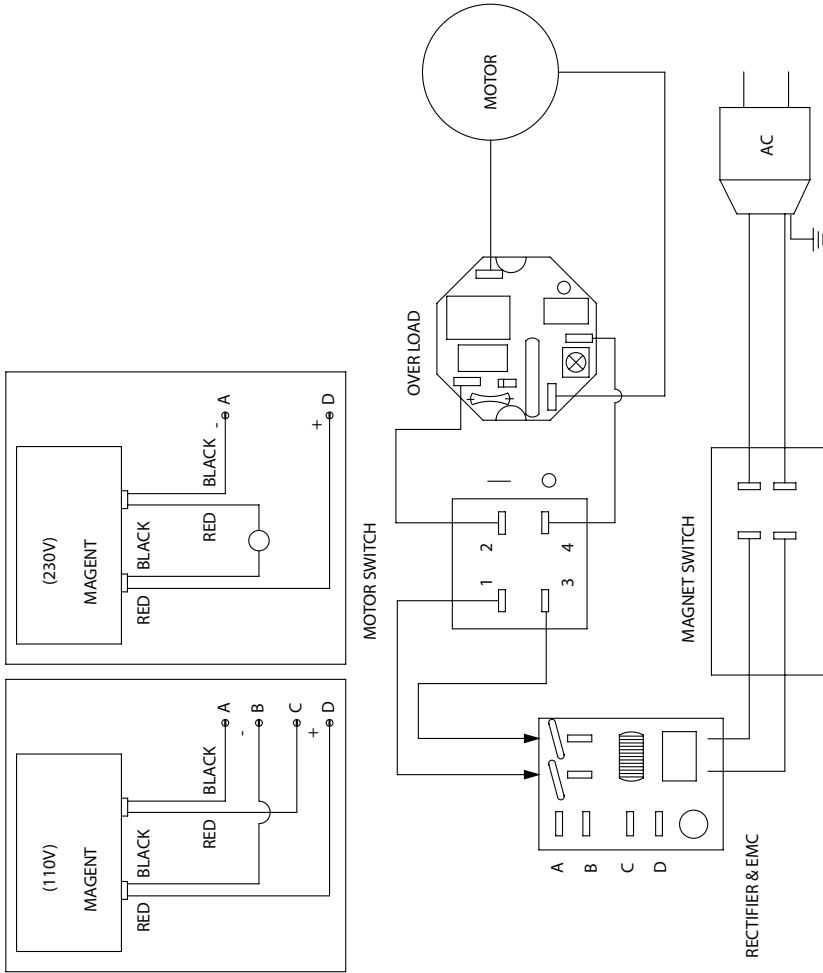

Exploded View

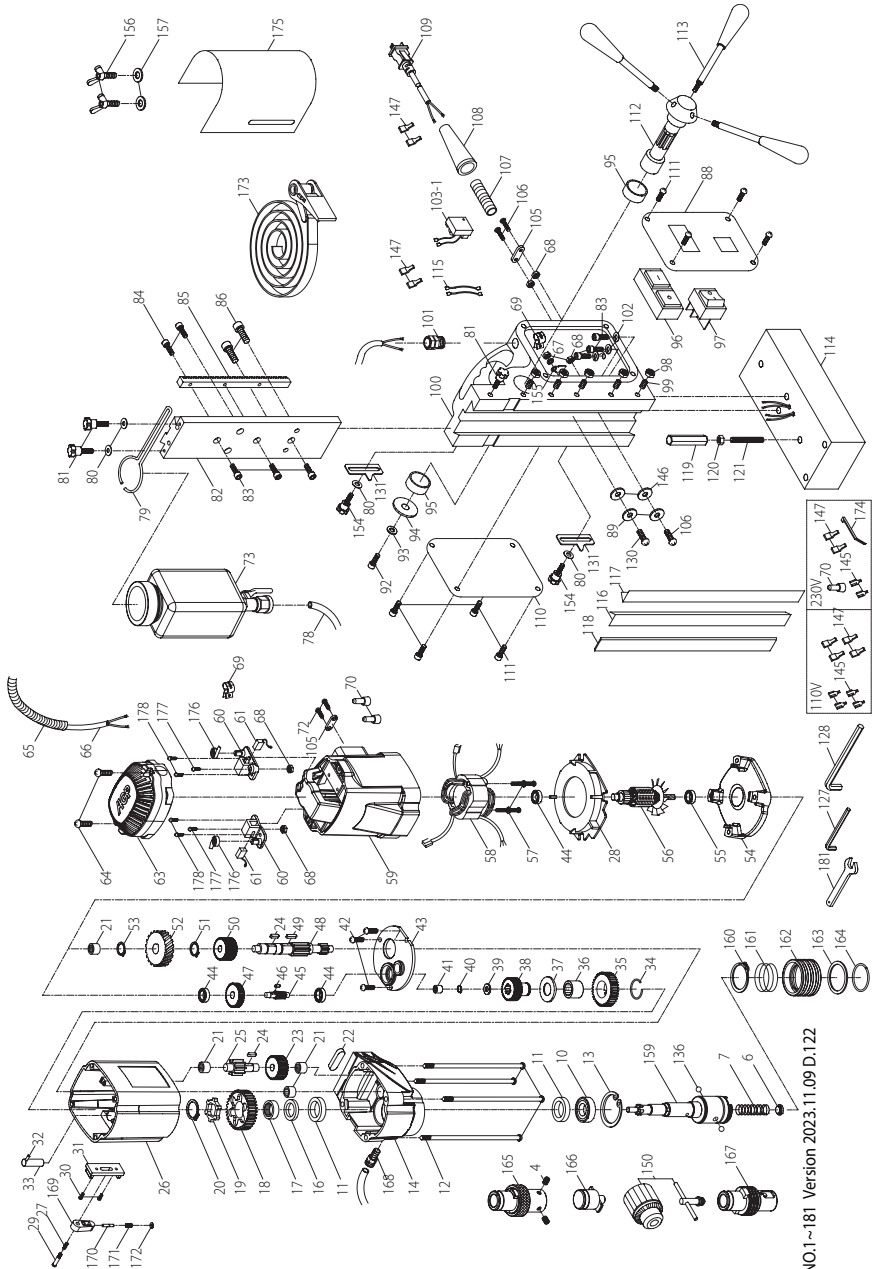

NO.1~181 Version 2023.11.09 D.122

Parts list

NO.	Parts Name	Q'TY	NO.	Parts Name	Q'TY
4	SOCKET SET SCREW (M8x7xP1.25)	2	50	DRILLING INTERMEDIATE GEAR (M1.25x26T)	1
6	WATER SEAL (Ø16x16)	1	51	EXTERNAL CIRCLIP (S-16)	1
7	SPRING (Ø1.5xØ13.3xØ16.6x16Tx100L)	1	52	LAY GEAR (M1.0x52T)	1
10	BALL BEARING (6205)	1	53	EXTERNAL CIRCLIP (S-14)	1
11	OIL SEAL (Ø22xØ32x7)	2	54	GEAR PLATE	1
12	PANHEAD MACHINE SCREW (M5x170xP0.8)	4	55	BALL BEARING (609)	1
13	INTERNAL CIRCLIP (R-52)	1	56	ARMATURE (220V-73x42x45)	1
14	GEAR HOUSING	1	57	PANHEAD TAPPING SCREW (M5x60)	2
16	BUSHING	1	58	STATOR (220V-73x42x45)	1
17	NEEDLE BEARING (TA 2210)	1	59	MOTOR HOUSING	1
18	TAP REVERSING GEAR (M1.5x33T)	1	60	CARBON BRUSH HOLDER (7x11)	2
19	TAP SPINDLE ENGAGEMENT GEAR	1	61	CARBON BRUSH (7x11x17)	2
20	EXTERNAL CIRCLIP (S-17)	1	63	MOTOR TAIL CASTING	1
21	NEEDLE BEARING (HK 1010)	4	64	PANHEAD TAPPING SCREW (M4x30)	2
22	PARALLEL KEY (4x4x30)	1	65	CABLE PROTECTOR (5/16"x45CM)	1
23	REVERSING DRIVE GEAR (M1.25x24T)	1	66	WIRE (1.25x2Cx65CM-VCTF)	1
24	PARALLEL KEY (5x5x12)	2	67	EXTERNAL STAR WASHER (M5)	1
25	REVERSING DRIVE GEAR (M1.5x12T)	1	68	HEX NUT (M4xP0.7)	6
26	LOWER GEAR CASE	1	69	CABLE CLAMP	2
27	SPRING (Ø1xØ9xØ11x11Lx4T)	1	70	CRIMP CAP CONNECTOR (C4)	3
28	FAN BAFFLE	1	72	PANHEAD TAPPING SCREW-B (M4x14)	2
29	SHOULDER SCREW	1	73	COOLANT TANK ASSEMBLY	1
30	FLAT HEAD MACHINE SCREW (M4x8xP0.7)	2	78	TUBE (Ø4xØ6x20CM)	1
31	SELECTOR BASE	1	79	COOLANT TANK BRACKET	1
32	SHIFT PIN (Ø6x19.5)	1	80	FLAT WASHER (Ø5xØ12x1)	4
33	SELECTOR COLLAR PIN (Ø12x41)	1	81	THUMB SCREW (M5x16)	3
34	RETAINING RING (Ø1.5xØ23xØ26)	1	82	SLIDE PLATE (L310.5MM)	1
35	TAP FORWARD GEAR (M1.25x42T)	1	83	SOCKET CAP SCREW (M6x20xP1.0)	6
36	NEEDLE BEARING (TA 2515)	1	84	SOCKET CAP SCREW (M5x16xP0.8)	2
37	THRUST WASHER (Ø25xØ40x1.5)	1	85	GEAR RACK (M1.5)	1
38	DRILLING SPINDLE GEAR (M1.25x27T)	1	86	SOCKET CAP SCREW (M8x16xP1.25)	2
39	THRUST RING (Ø816)	1	88	SWITCH PANEL (126.8x86.7x1.5T)	1
40	EXTERNAL CIRCLIP (S-8)	1	89	FLAT WASHER (Ø4xØ10x1)	2
41	NEEDLE BEARING (HK Ø810)	1	92	SOCKET CAP SCREW (M6-1.0 x 16)	1
42	PANHEAD MACHINE SCREW (M5x10xP0.8)	3	93	FLAT WASHER (Ø6xØ25x1)	1
43	GEAR PLATE	1	94	FLAT WASHER (Ø6xØ40x2.5)	1
44	BALL BEARING (608)	3	95	BUSHING (Ø28xØ32x12)	2
45	INPUT SHAFT (M1.0x8T)	1	96	MOTOR SWITCH (220V)	1
46	PARALLEL KEY (4x4x10)	1	97	MAGNET SWITCH (110V&220V)	1
47	INPUT GEAR (M0.7x50T)	1	98	HEX NUT (M5xP0.8)	5
48	INTERMEDIATE PINION (M1.25x11T)	1	99	SOCKET SET SCREW (M5x20xP0.8)	5
49	PARALLEL KEY (5x5x15)	1	100	STAND BODY	1

Parts list

NO.	Parts Name	Q'TY	NO.	Parts Name	Q'TY
101	CABLE GLAND (5/16")	1	147	SPADE TERMINAL BOOT	8
102	SPRING WASHER (M6)	3	150	CHUCK (1/2")	1
103-1	RECTIFIER & EMC (110V&220V)	1	154	THUMB SCREW (M5x8)	2
105	CABLE CLIP	2	155	EARTHING MARKING	1
106	PANHEAD MACHINE SCREW (M4x30xP0.7)	3	156	BUTTERFLY SCREW (M6x10xP1.0)	2
107	CABLE PROTECTOR (5/16"x7CM)	1	157	FLAT WASHER (Ø6xØ13x1)	2
108	CORD ARMOR	1	159	SPINDLE (Ø31)	1
109	POWER SUPPLY CABLE	1	160	INTERNAL CIRCLIP (IS42)	1
110	SIDE PANEL (126.8x86.7x1.5T)	1	161	SPRING (Ø2.5xØ43xØ48x3Tx25L)	1
111	PANHEAD MACHINE SCREW (M4x8xP0.7)	8	162	QUICK-RELEASE COLLAR (Ø58)	1
112	CRANK SPINDLE (Ø28)	1	163	THRUST WASHER (Ø42.6xØ51.8x2)	1
113	CRANK HANDLE	3	164	RETAINING RING (Ø2.5xØ39.6xØ44.6)	1
114	ELECTROMAGNET (179x80x48)	1	165	ANNULAR CUTTER ARBOR (Ø31)	1
115	WIRE LEAD (1015-16#18CM)	2	166	QUICK-RELEASE CHUCK ADAPTORS (Ø31)	1
116	GIB STRIP-LEFT (258MM)	1	167	UNIVERSAL TAP CHUCK (Ø31)	1
117	GIB STRIP-RIGHT (258MM)	1	168	PUSH LOCK FITTING (PT1/8"xØ6)	1
118	GIB TENSIONER (258x11x1.2T)	1	169	SELECTOR TAB	1
119	TRAVEL LIMITER STOP	1	170	DETENT PIN (Ø5x22)	1
120	HEX NUT (M8)	1	171	SPRING (Ø0.6xØ5.3xØ6.5x17Lx5T)	1
121	SOCKET SET SCREW (M8x100xP1.25)	1	172	E-CLIP (E-3)	1
127	HEX KEY (M2.5)	1	173	SAFETY BELT	1
128	HEX KEY (M4)	1	174	ZIP TIE (2.5x100MM)	1
130	PANHEAD MACHIME SCREW (M4x16xP0.7)	1	175	CHIP GUARD	1
131	DEPTH LOCK LEVER	2	176	BRUSH SPRING (0.35x3x3T)	2
136	CHECK BALL (Ø8)	2	177	PANHEAD MACHINE SCREW (M4x10xP0.7)	2
145	FEMALE SPADE TERMINAL	4	178	PANHEAD TAPPING SCREW (M4x12)	4
146	RUBBER WASHER (Ø4xØ11x1)	2	181	WRENCH (M8)	1

