



Test Report issued under the responsibility of:



**TEST REPORT  
IEC 60745-2-1**

**Safety of Hand-Held Motor-Operated Electric Tools  
Part 2: Particular requirements for drills and impact drills**

**Report reference No.** ..... : 6041644.50A  
**Date of issue** ..... : 2018-11-26  
**Total number of pages** ..... : 68 pages  
**CB Testing Laboratory** ..... : DEKRA Testing and Certification (Shanghai) Ltd.  
**Address** ..... : 3F, #250 Jiangchangsan Road, Building 16, Headquarter Economy Park Shibei Hi-Tech Park, Zhabei District, Shanghai, 200436, China

**Applicant's name** ..... : LEE YEONG INDUSTRIAL CO., LTD.  
**Address** ..... : No.2, Kejia Rd., Douliu City, Yunlin County 64057, Taiwan

**Test specification:**

**Standard** ..... : IEC 60745-2-1:2003 (Second Edition)+A1:2008 used in conjunction with IEC 60745-1:2006 (Fourth Edition)  
**Test procedure** ..... : CB Scheme  
**Non-standard test method** ..... : N/A

**Test Report Form No.** ..... : IEC60745\_2\_1D

**Test Report Form(s) Originator** ..... : Electrosuisse  
**Master TRF** ..... : Dated 2010-02

**Copyright © 2010 Worldwide System for Conformity Testing and Certification of Electrotechnical Equipment and Components (IECEE), Geneva, Switzerland. All rights reserved.**

This publication may be reproduced in whole or in part for non-commercial purposes as long as the IECEE is acknowledged as copyright owner and source of the material. IECEE takes no responsibility for and will not assume liability for damages resulting from the reader's interpretation of the reproduced material due to its placement and context.

If this Test Report Form is used by non-IECEE members, the IECEE/IEC logo and the reference to the CB Scheme procedure shall be removed.

**This report is not valid as a CB Test Report unless signed by an approved CB Testing Laboratory and appended to a CB Test Certificate issued by an NCB in accordance with IECEE 02.**

**Test item description** ..... : Diamond Core Drill  
**Trade Mark** ..... : AGP  
**Manufacturer** ..... : LEE YEONG INDUSTRIAL CO., LTD.  
 No.2, Kejia Rd., Douliu City, Yunlin County 64057, Taiwan  
**Model/Type reference** ..... : DM6P; **DBM200-3; EVO2 PWD; EVO2 DWD;EVO2 PW;EVO2 DW; MCM200;KDMM2000;MT-19A;MT-19P;MT-18P;MT-18A; CAR201;QDM-150D;QDM-150W;C-BMH-160;BB1004;HSD-6P; DM6D; DMC6P; DMC6D; DM62; DD62; DD160; EVO20-PDSI; MDB-180P**  
**Ratings** ..... : DM6P; **DBM200-3; EVO2 PWD; EVO2 DWD;EVO2 PW;EVO2 DW; MCM200;KDMM2000;MT-19A;MT-19P;MT-18P;MT-18A;**

**CAR201;QDM-150D;QDM-150W;C-BMH-160;BB1004;HSD-6P;**

DM6D; DMC6P; DMC6D:

220-240 V; 50-60 Hz; 2000 W;  $n_0=930/1520/4270 \text{ min}^{-1}$ ; Class I

110-120 V; 50-60 Hz; 1700 W;  $n_0=930/1520/4270 \text{ min}^{-1}$ ; Class I

DM62; DD62; DD160; **EVO20-PDSI; MDB-180P:**

220-240 V; 50-60 Hz; 2000 W;  $n_0=1250/1900 \text{ min}^{-1}$ ; Class I

110-120 V; 50-60 Hz; 1700 W;  $n_0=1250/1900 \text{ min}^{-1}$ ; Class I

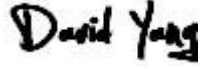
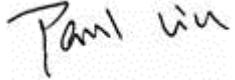
<b>Testing procedure and testing location:</b>	
<input checked="" type="checkbox"/> <b>CB Testing Laboratory:</b>	DEKRA Testing and Certification (Shanghai) Ltd.
Testing location/ address .....	3F., #250 Jiangchangsan Road, Building 16, Headquarter Economy Park Shibe Hi-Tech Park, Zhabei District, Shanghai, 200436, China
<input type="checkbox"/> <b>Associated CB Laboratory:</b>	
Testing location/ address .....	
Tested by (name + signature) .....	David Yang
Approved by (+ signature).....	Paul Liu
	 
<input type="checkbox"/> Testing procedure: TMP	
Tested by (name + signature) .....	
Approved by (+ signature).....	
Testing location/ address .....	
<input type="checkbox"/> Testing procedure: WMT	
Tested by (name + signature) .....	
Witnessed by (+ signature) .....	
Approved by (+ signature).....	
Testing location/ address .....	
<input type="checkbox"/> Testing procedure: SMT	
Tested by (name + signature) .....	
Approved by (+ signature).....	
Supervised by (+ signature) .....	
Testing location/ address .....	
<input type="checkbox"/> Testing procedure: RMT	
Tested by (name + signature) .....	
Approved by (+ signature).....	
Supervised by (+ signature) .....	
Testing location/ address .....	

**List of Attachments (including a total number of pages in each attachment):**

Test report constituents:

- 6041644.50A covering IEC 60745-1 and IEC 60745-2-1 (total 68 pages)
- 6041644.50B covering EU group differences to IEC 60745-1 (total 3 pages)
- 6041644.50C covering EU group differences to IEC 60745-2-1 (total 2 page)

**Summary of testing:**

The tools tested passed all examinations of the applied standards mentioned on page 1 "Test specification" and on page 4 "General remarks".

**Tests performed (name of test and test clause):**

All appl. clauses of the standard have been done at CBTL except the test as below:

Noise and vibration tests were done at CSIC No.711 Research Institute

**Testing location:**

DEKRA Testing and Certification (Shanghai) Ltd.  
3F, #250 Jiangchangsan Road, Building 16,  
Headquarter Economy Park Shibe Hi-Tech Park,  
Zhabei District, Shanghai, 200436, China

Testing and Calibration Laboratory of vibration and noise of CSIC No.711 Research Institute  
No. 3111, Hua'ning Road, Shanghai, China

**Summary of compliance with National Differences:**

The tool is tested to and complies with EN 60745-1:2009 + A11:2010 and EN 60745-2-1:2010, thus complying with the EU group differences.

Noise level:  $L_{pA}$ : 97,0 dB(A)  $L_{wA}$ : 108,0 dB(A)  $K = 3$  dB(A)  
Vibration level:  $a_n$ : 10,9 m/s<sup>2</sup>  $K = 1,5$  m/s<sup>2</sup>

**Note: Vibration test were performed with 80 mm drill bit according to instructions under hand-held mode.**

**Copy of marking plate**

Note: Marking labels of DM6P; DBM200-3; EVO2 PWD; EVO2 DWD; EVO2 PW; EVO2 DW; MCM200; KDMM2000; MT-19A; MT-19P; MT-18P; MT-18A; CAR201; QDM-150D; QDM-150W; C-BMH-160; BB1004; HSD-6P; DM6D; DMC6P; DMC6D; DM62; DD62; DD160; EVO20-PDSI; MDB-180P are same, only the rated no-load speed is different due to different ratio of gear box.

<b>Test item particulars</b> .....	
Class of tool .....	Class I
Method of supply cord attachment.....	Type Y
Duty conditions .....	Normal
Type of operation.....	Continuous
Degree of protection .....	-
<b>Possible test case verdicts:</b>	
- test case does not apply to the test object .....	N/A
- test object does meet the requirement .....	P (Pass)
- test object does not meet the requirement .....	F (Fail)
<b>Testing</b> .....	
Date of receipt of test item .....	2017-07-26
Date (s) of performance of tests .....	From 2017-06-27 to 2017-07-26
Modification-1 .....	From 2018-10-27 to 2018-11-27
<b>General remarks:</b>	
<p>The test results presented in this report relate only to the object tested.  This report shall not be reproduced, except in full, without the written approval of the Issuing testing laboratory.  "(see Enclosure #)" refers to additional information appended to the report.  "(see appended table)" refers to a table appended to the report.</p> <p>Throughout this report, a comma is used as the decimal separator.  The tools were tested and complies with following standards:  IEC 60745-1:2006; IEC 60745-2-1:2003+A1:2008  EN 60745-1:2009+A11:2010; EN 60745-2-1:2010</p> <p><b>This report was based on report with reference No. 6010547.50 dated 2017-07-26 and replaces it. (CB certificate NL- 47971, dated 2017-07-31).</b></p>	
Manufacturer's Declaration per sub-clause 6.2.5 of IECEE 02:	
The application for obtaining a CB Test Certificate includes more than one factory location and a declaration from the Manufacturer stating that the sample(s) submitted for evaluation is (are) representative of the products from each factory has been provided.....	<input type="checkbox"/> Yes <input checked="" type="checkbox"/> Not applicable
When differences exist; they shall be identified in the General product information section.	
<b>Name and address of factory (ies)</b> .....	LEE YEONG INDUSTRIAL CO., LTD. No.2, Kejia Rd., Douliu City, Yunlin County 64057, Taiwan

**General product information:**

This machine is for the intended purpose of diamond core drilling of concrete, masonry, stone and similar materials. DM6P; DBM200-3; EVO2 PWD; EVO2 DWD;EVO2 PW;EVO2 DW; MCM200;KDMM2000;MT-19A;MT-19P;MT-18P;MT-18A; CAR201;QDM-150D;QDM-150W;C-BMH-160;BB1004;HSD-6P; DM6D; DMC6P; DMC6D; DM62; DD62 and DD160; EVO20-PDSI; MDB-180P are identical. The difference for DM6P; DBM200-3; EVO2 PWD; EVO2 DWD;EVO2 PW;EVO2 DW; MCM200;KDMM2000;MT-19A;MT-19P;MT-18P;MT-18A; CAR201;QDM-150D;QDM-150W;C-BMH-160;BB1004;HSD-6P; DM6D; DMC6P; DMC6D and DM62; DD62; DD160; EVO20-PDSI; MDB-180P is only the rated no-load speed due to the ratio of the gear box is different. The handles of these models can be D or P type, see photos for details.

Models	No-load speed
DM6P; <b>DBM200-3; EVO2 PWD; EVO2 DWD;EVO2 PW;EVO2 DW;</b> <b>MCM200;KDMM2000;MT-19A;MT-19P;MT-18P;MT-18A; CAR201;QDM-150D;QDM-150W;C-BMH-160;BB1004;HSD-6P;</b> DM6D; DMC6P; DMC6D	$n_0=930/1520/4270 \text{ min}^{-1}$
DM62; DD62; DD160; <b>EVO20-PDSI; MDB-180P</b>	$n_0=1250/1900 \text{ min}^{-1}$

**Modification 1 report:**

The original Test Report Ref. No. 6010547.50 dated 2017-07-26 modified on 2018-11-26 to include the following changes and/or addition, which were considered technical modifications.

- Add new types. New types are same as previous types.
- Vibration retest according to instructions. (with 80 mm drill bit)

After review, 1 test considered was necessary. See summary of testing for details.

IEC 60745-2-1			
Clause	Requirement + Test	Result - Remark	Verdict
<b>5</b>	<b>GENERAL CONDITIONS FOR THE TESTS</b>		
5.2	A single tool subjected to all tests, except as specified, and it withstood all relevant tests		P
	A separate sample subjected to tests requiring tool modifications or disassembly after test performed		P
	Additional samples of tools designed for different supply voltages subjected to tests		N/A
	Testing of components necessitated subjecting additional samples of these components to tests		N/A
	Cumulative stress resulting from successive tests on electronic circuits avoided		N/A
	Components replaced or additional samples used as necessary		N/A
5.3	Tests conducted in order of clauses		P
	Tests specified not deemed applicable based on construction of the tool		P
5.4	The tool and its movable parts tested in most unfavourable position in normal use		N/A
5.5	User adjustable controls and switching devices tested in their most unfavourable settings		P
	Electronic speed control devices set at their highest speed		P
A	The mechanical device is adjusted to the lowest range		P
5.6	Tests conducted in a draught-free location, and unless otherwise specified, in $(20 \pm 5) ^\circ\text{C}$		P
	Tests conducted at $(23 \pm 2) ^\circ\text{C}$ due to temperature limited temperature sensitive device		N/A
5.7.2	Tool rated for more than one rated voltage tested at the most unfavourable voltage (V) .....		N/A
5.8	Tool tested with attachments resulting in most unfavourable conditions		P
5.9	Tool tested with appropriate flexible cord, except as specified		P
5.10	Accessible metal parts of class I tools not connected to an earthing terminal checked for compliance with the appropriate requirements for class II construction		N/A
	Accessible non-metallic parts of class I tools checked for compliance with appropriate requirements specified for class II construction		P
5.11	Parts of tools class I or class II tools operating at safety extra-low voltage checked for compliance with requirements specified for class III tools		N/A
5.13	Heating element tested with the motor running		N/A

IEC 60745-2-1			
Clause	Requirement + Test	Result - Remark	Verdict
	Heating elements incorporated in the tool connected to a separate supply, unless otherwise specified		N/A
5.14	Attachments performing a function within the scope of a relevant parts 2, tested according to that part 2		N/A
	Other attachments tested in accordance with manufacturer's instructions		N/A
	In the absence of manufacturer's instructions, tool operated continuously using a load resulting in rated input or rated current (VA, A)..... :		N/A
5.15	Tool loaded avoiding additional stresses such as side thrust when torque was to be applied		P
5.16	Tools operating at safety extra-low voltage and sold with their supply transformer tested using the supply transformer		N/A

7	CLASSIFICATION		
7.1	Tool is Class I, II, or III with respect to protection against electric shock .....	Class I	P
7.2	Degree of protection against harmful ingress of water per IEC 60529 .....		N/A
	Required degree of protection other than IPX0 specified by manufacturer or in relevant part 2 .....		N/A

8	MARKINGS AND INSTRUCTIONS		
8.1	Tool marked with rated voltage(s) or rated voltage range(s) (V) .....	220-240 V 110-120 V	P
	Tool for star-delta connection clearly marked with the two rated voltages (e.g. 230 Δ / 400 Y V) .....		N/A
	Nature of supply/frequency with symbol for nature of supply placed next to rated voltage (Hz)..... :	50-60 Hz	P
	Rated input or current marked (W or A)..... :	110-120 V: 1700 W 220-240 V: 2000 W	P
	Rated input or rated current corresponds to highest loading possible for a tool with alternative components selectable by a control device		N/A
	Manufacturer's name, or trade mark, or identification mark and address of manufacturer or an agent responsible for marketing the tool .....	See marking label	P



IEC 60745-2-1			
Clause	Requirement + Test	Result - Remark	Verdict
	Model or type reference..... :	DM6P; DBM200-3; EVO2 PWD; EVO2 DWD;EVO2 PW;EVO2 DW; MCM200;KDMM2000;MT-19A;MT-19P;MT-18P;MT-18A; CAR201;QDM-150D;QDM-150W;C-BMH-160;BB1004;HSD-6P; DM6D; DMC6P; DMC6D; DM62; DD62; DD160; EVO20-PDSI; MDB-180P	P
	Class II symbol for class II tools..... :		N/A
	IP number other than IPX0..... :		N/A
	Tool provided with "WARNING – To reduce the risk of injury, user must read instruction manual" or the sign M002 of ISO 7010 <sup>8</sup> )	Symbol M002 of ISO 7010	P
	Additional markings not leading to misunderstanding permitted	CE marking and WEEE symbol	P
8.1	A Rated no-load speed (revolutions/minute)..... :	$n_0=930/1520/4270 \text{ min}^{-1}$ $n_0=1250/1900 \text{ min}^{-1}$	P
	Maximum capacity of the chuck (millimetres)..... :	-	N/A
8.2	Rated operating time, or rated operating time and rated resting time, respectively, marked on a short-time or intermittent operation tool, except when operating time limited by construction of tool..... :		N/A
	Rated operating time precedes rated resting time, and they are separated by an oblique stroke		N/A
8.3	Correct use of symbol for voltage ranges and different voltage levels	110-120 V, 220-240 V	P
8.4	Change in voltage clearly discernible		N/A
	Correct Wiring diagram fixed to tool		N/A
8.5	Rated power input..... :		N/A
8.6	Use of correct symbols		P
	Correct dimensions and use for Class II symbol		N/A
	Other units and their symbols same as international standardised system		P
	No misunderstanding with use of additional symbols		P
8.7	A connection diagram affixed to a tool with more than two supply conductors, except when correct mode of operation is obvious as specified		N/A
	The earthing conductor not a supply conductor		P
	Wiring diagram indicates how the windings are to be connected for tools for star-delta connection		N/A
8.8	Terminals, except for type Z attachments, marked on non-removable part with specified symbols		N/A

IEC 60745-2-1			
Clause	Requirement + Test	Result - Remark	Verdict
	Terminal exclusively for neutral connection marked with "N"		N/A
	Earthing terminal marked with specified symbol		P
8.9	Switches, which may result in a hazard, marked accordingly using universally comprehensible symbol, or located to indicate which part of tool they control		P
8.10	"Off" position indicated by figure O of IEC 60417-5008 (DB:2002-10) when a hazard could result by unexpected start up		N/A
	Figure O not used for any other indication		P
	Position of moving contacts of mains switch correspond to indications for different positions of its operating means		N/A
8.11	Regulating devices and the like provided with markings as specified		P
	Figures used for different positions with O for "off" position, and figures reflecting greater output for other positions		N/A
8.12	Instruction manual and safety instructions provided together with an explanation of the symbols		P
	Instructions legible and contrasting in the official language(s) of the country where tool is sold, and include name and address of manufacturer, or supplier, or agent marketing the tool		P
8.12.1	Safety instructions in English are verbatim and in any other official language are equivalent		P
	Format of all Safety Warnings differentiate the context of all clauses by font or similar means and as illustrated in 8.12.1.1		P
8.12.1.1	General Power Tool Safety Warnings		P
A	Wear ear protectors when impact drilling. Exposure to noise can cause hearing loss		N/A
	Use auxiliary handle(s) if supplied with the tool. Loss of control can cause personal injury		P
	Hold power tool by insulated gripping surfaces, when performing an operation where the cutting accessory may contact hidden wiring or its own cord		P
8.12.1.2	Order of the Safety Instructions are in accordance with this clause		P
8.12.2	Warnings required by this clause included in Instruction Manual when Safety Instructions are separate from instruction Manual		N/A
	Warnings in English are verbatim and in any other official language are equivalent		P

IEC 60745-2-1			
Clause	Requirement + Test	Result - Remark	Verdict
	Instruction Manual provided with the required information in a) to d) of this clause as appropriate		P
8.13	Markings easily legible and withstood durability test		P
	Signs are in contrast to their background, clearly legible from a distance of not less than 500 mm		P
	Label material, grade designation, ink and printing process		P
	Signs complied with blue colour requirements of ISO 3864-2		N/A
8.14	Markings in 8.1 to 8.5 on a main part of the tool		P
	Markings in 8.1, 8.2, 8.3, and 8.5 placed together		P
	Markings clearly discernible from outside of the tool, but if necessary, after removal of a cover without aid of a tool		P
	Indications for switches and controls placed on or in vicinity of components		P
8.15	Thermal link or fuse-link marked appropriately		N/A

<b>9</b>	<b>PROTECTION AGAINST ACCESS TO LIVE PARTS</b>		
9.1	Accessible part not considered live		N/A
	- extra-low a.c. voltage: peak values not exceeding 42.4 V		N/A
	- extra-low d.c. voltage: not exceeding 42.4 V		N/A
	- or separated from live parts by protective impedance, d.c. current not exceeding 2 mA	See appended Table 9.1	N/A
	- or separated from live parts by protective impedance, a.c. peak value not exceeding 0.7 mA	See appended Table 9.1	N/A
	- for peak value 42.4 V up to and including 450 V capacitance not exceeding 0.1 $\mu$ F	See appended Table 9.1	N/A
	- for peak value 450 V up to and including 15 kV capacitance not exceeding 0.1 $\mu$ F	See appended Table 9.1	N/A
9.2	Probe of Fig 1 did not contact live parts with detachable parts removed		P
	Probe of Fig 1 did not contact live parts of the lamp with detachable parts removed		N/A
	Screw type fuses or screw-type miniature circuit breakers accessible without aid of a tool excluded from this requirement		N/A
	Probe of Fig 1 did not contact live parts or live parts protected only by lacquer, enamel, ordinary paper, cotton, oxide film, beads, or sealing compound applied through an opening with 20 N force		P
9.3	Test pin of Fig 2 did not contact live parts, through openings in class II tools or class II constructions		P

IEC 60745-2-1			
Clause	Requirement + Test	Result - Remark	Verdict
9.4	Probe of Fig 1 did not contact basic insulation through openings in Class II tools or Class II constructions with all detachable parts removed		P

10	STARTING		
10.1	Motors start under normal voltage conditions		P
	Starting ten times at 0.85 times rated voltage without load (V) .....	93,5 V, 187 V	P
10.2	Centrifugal and other automatic starting switches operated reliably 10 times at 1.1 of the rated voltage (V) .....		N/A
10.3	Overload protection devices did not operate under normal starting conditions as confirmed by 10.1 and 10.2		N/A

11	INPUT AND CURRENT		
11.1	Marked power input or current is at least 110% of measured no-load input or current .....	See appended Table 11.1	P

12	HEATING		
12.1	Excessive temperatures not attained under normal load .....	See appended Table 12.1	P
	Measurements for heating elements repeated as specified		N/A
12.2	Loading conditions during temperature test .....	See appended Table 12.1	P
	Heating elements tested to IEC 60335-1 at 1.06 times rated voltage		N/A
A	Tool was operated continuously with the impact mechanism disengaged, while the torque applied to the spindle was 80% of the torque necessary to attain rated input or rated current		P
12.3	When possible, temperature rises of uniform windings determined by resistance method .....	See appended Table 12.3	P
	Temperature rise of electrical insulation, other than windings, measured on surface of insulation .....		P
A	The temperature-rise limit specified for the external enclosure does not apply to the enclosure of the impact mechanism		P
12.4	Tool operating time .....	See appended Table 12.1	P
12.5	Temperature rises did not exceed values in Table 1, except as allowed by 12.6		P
	Protective devices did not operate		N/A
	Sealing compounds did not flow		P

IEC 60745-2-1			
Clause	Requirement + Test	Result - Remark	Verdict
12.6	When winding temperatures exceeded values in Table 1, three additional samples successfully subjected to following tests:		N/A
	a) Heat treatment for 240 h at the specified cabinet temperature (°C): .....		N/A
	b) No inter-turn short circuit after oven treatment		N/A
	c) Humidity treatment in accordance with 14.3		N/A
	d) No excessive leakage current after humidity treatment .....	See appended Table 13.1C	N/A
	No flashover or breakdown occurred during electric strength after humidity treatment.....	See appended Table 15.2A	N/A

<b>13 LEAKAGE CURRENT</b>			
13.1	Leakage current was not excessive .....	See Tables 13.1A-13.1E	P
	Protective impedance disconnected		N/A
13.2	Leakage current measured using circuit of Fig. 10		P

<b>14 MOISTURE RESISTANCE</b>			
14.1	Degree of protection for tool enclosure according to tool classification (IP Code) .....		N/A
14.1.1	Tool not connected to the supply and turned continuously through most unfavourable positions		N/A
	Lightest permissible flexible cord with smallest cross-sectional area specified on Table 8 used on the tool with type X attachment (A, mm <sup>2</sup> ).....		N/A
	Other tools tested as delivered		N/A
14.1.2	Tool rated IPX1 through IPX7 subjected to applicable tests of IEC 60529		N/A
	For IPX7 test, tool immersed in water containing 1.0 % NaCl		N/A
	Tool withstood electric strength test of 15 after moisture treatment	See appended Table 15.2B	N/A
	No trace of water on insulation causing reduction of creepage and clearance below values in 28.1		N/A
14.2	No trace of water on insulation causing reduction of creepage and clearance below those in 28.1 after spillage of liquid test		N/A
	Tool withstood electric strength test of 15 after spillage treatment	See appended Table 15.2B	N/A
	Tool subjected to test of 14.3 after standing in normal test –room atmosphere for 24 h		N/A
14.3	Tool subjected to humidity treatment test for 48 h		P
	Relative humidity (93 ± 2) %	93 %	P

IEC 60745-2-1			
Clause	Requirement + Test	Result - Remark	Verdict
	Temperature (20 - 30 °C ± 1K )	25 °C	P
	No excessive leakage after humidity treatment..... :	See appended Table 13.1D	P
	No flashover or breakdown occurred during electric strength after humidity treatment..... :	See appended Table 15.2A	P
14.4	User not subject to an increased risk of electrical shock by liquid system during foreseeable use		P
	Tool operated for 1 min in each mode and did not exceed maximum allowed leakage current	See appended Table 13.1E	P
	Tool did not exceed maximum allowable leakage current after drying for 24 h at ambient temperature	See appended Table 13.1E	P
14.5	Liquid system withstood the pressure in normal use without leaking		P
	Tool did not exceed maximum allowable leakage current during pressure application	See appended Table 13.1E	P
	Tool did not exceed maximum allowable leakage current after drying for 24 h at ambient temperature	See appended Table 13.1E	P
14.6	Residual current devices complied with IEC 61540 and met requirements a) to c)		P
	a) RCD disconnected only both mains conductors when leakage exceeded 10 mA with a maximum response of 300 ms		P
	Test conducted according to 9.9.2 of IEC 61540, and earthing conductor stayed connected		P
	b) RCD operated correctly for all 50 cycles		P
	c) RCD cannot be removed during use or routine normal maintenance (i.e., residual current device fixed to tool or power supply cord connected to tool)		P
	RCD fitted in supply cord provided with Type Y or Z attachment for connection to supply cord and interconnecting cord		P

<b>15</b>	<b>ELECTRIC STRENGTH</b>		
15.1	Protective impedance disconnected		
15.2	No flashover or breakdown occurred during the test with the output current at least than 200 mA and the applied measured voltage +/- 3% .....	See Tables 15.2	P
	The insulation coating withstood the applied potential with the 5 kPa force applied		N/A
	For the tool with integral heating elements, test voltages specified in IEC 60335-1 applied to the heating elements only and not to other parts of tool		N/A

<b>16</b>	<b>OVERLOAD PROTECTION OF TRANSFORMERS AND ASSOCIATED CIRCUITS</b>		
-----------	--	--	--

IEC 60745-2-1			
Clause	Requirement + Test	Result - Remark	Verdict
16.1	No excessive temperatures occurred during short circuit in transformer or circuits associated with it for a tool supplied from a transformer..... :	See Table 16.1	N/A
	Power limited by (short-circuit protective device) ... :		—
	Insulation on conductors was within 15 K of Table 1		N/A
	Transformer windings complied with Clause 18.9		N/A
	Transformer complies with IEC 61558-1		N/A

<b>17</b>	<b>ENDURANCE</b>		
17.1	No hazards due to extended normal use		P
17.2	No load intermittent operation (2 x 24 h)		N/A
	Number of operations .....	-	—
	Number of hours for each operation .....	-	—
	Test voltage at each operation (V) .....	-	—
	Rate of operation (100s "on", 20s "off")..... :	-	—
	Test positions selected .....	-	—
	Operation time for each position .....	-	—
R	For Impact drills: The impact mechanism shall remain disengaged for 12h at 1.1x and 12h at 0.9x rated voltage		N/A
	Number of operations .....	2	P
	Number of hours for each operation .....	24	P
	Test voltage at each operation (V) .....	132 V, 99 V and 264 V, 198 V	P
	Rate of operation (100s "on", 20s "off")..... :	100 s "on" 20 s "off"	P
	Test positions selected .....	3 positions	P
	Operation time for each position .....	8 h	P
	4x6h in test apparatus (Figure 101)		P
	During the test, an axial force was applied to the impact drill through a resilient medium		N/A
	The impact mechanism failed mechanically during the test without causing an accessible part to become live		P
	Servicing of carbon brushes and lubricant		N/A
	Forced cooling or rest periods if temperature exceeded values in Table 1		N/A
	No electrical or mechanical failure		P
	No insulation damage		P
	No loose contacts or connections		P
	No flashover or breakdown occurred after spillage treatment .....	See Table 15.2C	P

IEC 60745-2-1			
Clause	Requirement + Test	Result - Remark	Verdict
	No operation of overload protection devices		N/A
17.3	Tools with Centrifugal switches operated for 10,000 cycles		N/A
	Number of operations under normal load .....		N/A
	Rate of operations (s "on", s "off") .....		N/A
	Test voltage 0.9 x rated Voltage (V).....		N/A
	No electrical or mechanical failure		N/A
	No insulation damage		N/A
	No loose contact or connections		N/A
	No flashover or breakdown occurred .....	See Table 15.2D	N/A
	No opening of overload protection devices		N/A

<b>18</b>	<b>ABNORMAL OPERATION</b>		
18.1	No hazard due to abnormal operation		P
	Fuses, thermal cut-outs, over current protection devices used to provide the necessary protection		N/A
18.2	Tool with heating elements		N/A
	Tool with a control device limiting temperature		N/A
	Only one abnormal condition simulated each time		N/A
	Tests of Clauses 18.2-18.6 conducted consecutively when more than one test applicable to the same tool		N/A
	Tool tested until a non-self-resetting thermal cut-out operated, or until steady conditions		N/A
	Test repeated on a second sample when a heating element permanently open-circuited		N/A
	Only one abnormal condition simulated each time		N/A
18.3	Tool with heating elements tested under the conditions of heating test, except with restricted heat dissipation		N/A
	Test voltage provided a power 0.85 times rated power input (V).....		—
18.4	Tool cooled down to room temperature and test of 18.3 repeated		N/A
	Test voltage provided a power input of 1.24 times rated power input (V) .....		—
18.5	Tested as in heating test, under normal operation with control limiting the temperature short-circuited		N/A
	Test voltage provided a power input of 1.15 times rated power input (V) .....		—
	Multiple controls short-circuited one at a time		N/A



IEC 60745-2-1			
Clause	Requirement + Test	Result - Remark	Verdict
18.6	Test on class I tool with tubular sheathed and embedded heating elements		N/A
	Test repeated with the supply polarity reversed and other end of element connected to earth		N/A
18.7	No load test for 1 min on cutting tools incorporating a commutator motor		P
	Test voltage 1.3 times rated voltage, or upper limit of voltage range (V) .....	156 V, 312 V	—
	After the tests of 18.2 to 18.7, safety of tool not impaired, and windings and connections not loose		P
18.8	Test on tools with induction motor and with moving parts locked		N/A
	a) Tool with a starting torque less than full-load torque		N/A
	Duration of locked conditions (s) .....	-	—
	b) Tool started by hand		N/A
	Duration of locked condition (s) .....	-	—
	c) tool with moving parts liable to be jammed, or moving parts that can be stopped by hand with the motor switched on		N/A
	Duration of locked condition (s) .....	-	—
	After the test, or at the instant of operation of fuses, thermal cut-outs, motor operated devices, and the like, the temperature of the windings complied with the values in Table 3		N/A
	Max winding temperature recorded (°C) .....	-	—
18.9	Test on tools with 3-phase motors with one phase disconnected		N/A
	30 s tests for tool switched on by hand or continuously loaded by hand; cold started		N/A
	5 min test for other tools		N/A
	After the test, or at the instant of operation of fuses, thermal cut-outs, motor protection devices, and the like, the temperature of the windings complied with the limits in Table 3		N/A
	Max winding temperature recorded (°C) .....	-	—
18.10	No hazards occurred under fault conditions of 18.10.2		P
	Circuits complied with 18.10.1 and not subjected to fault conditions of 18.10.2		N/A
	Test of 18.10.3 conducted when safety of tool under a fault condition depended on operation of a miniature fuse-link complying with IEC 60127-3		N/A

IEC 60745-2-1			
Clause	Requirement + Test	Result - Remark	Verdict
	Tool withstood the particular test as a conductor of a PCB open-circuited, and		P
	– base material of PCB withstood test of Annex F,		N/A
	– creepage or clearances between live parts and accessible metal parts not reduced below values in 28 due to loosened conductors, and		P
	– tool withstood tests of 18.10.2 with the open-circuited conductor bridged		P
18.10.2	Fault conditions a) to f) conducted as applicable	See Table 18.10.2	P
18.10.3	Tests repeated with fuse-link replaced by an ammeter when during fault conditions of 18.10.2, safety of the tool depended on operation of a miniature fuse-link complying with IEC 60127-3,	See Table 18.10.2	N/A
	– Circuit not considered to be adequately protected when current measured was ... 2.1 times the rated current of fuse-link, and test conducted with fuse-link short-circuited (A)..... :	-	N/A
	– Circuit considered adequately protected when current measured was — 2.75 times the rated current of fuse-link (A) ..... :	-	N/A
	– Fuse-link short-circuited when current measured was 2.1-2.75 times the rated current of fuse-link, and test conducted as follows (A) ..... :	-	N/A
18.10.4	Tools incorporating electronic devices are so designed that no hazard results in the event of a failure in the electronic equipment	See Table 18.10.2	N/A
	Tool operated for 1 min, at a voltage equal to the rated voltage or the mean value of the voltage range, at no-load with the electronic device short-circuited.		N/A
	No hazard resulted when test repeated with electronic device open-circuited		N/A
	No damage due to fire and mechanical damage impairing safety and protection against electric shock following the tests of 18.10.1 to 18.10.4, and		N/A
	- Current through protective impedance was less than limits of Clause 9.1 (A) ..... :	-	N/A
	Tool considered to have withstood the test when speed-limiting device operated		N/A
18.11	Switches and devices for motor reversal withstood stresses occurring when rotation reversed 25 times under running conditions at rated voltage or upper limit of rated voltage range at no-load (V)..... :	-	N/A
18.12	Class I tool with class II construction and class II tool operated under extreme overload conditions without impairing protection against electric shock		P

IEC 60745-2-1			
Clause	Requirement + Test	Result - Remark	Verdict
	A separate sample operated for 15 min, until the tool open-circuited, or flame appeared		P
	Test circuit (KVA) .....	20	—
	160% normal load test current (A) .....	29,3 / 14,7	—
	Overload condition existed for (_min, _sec) .....	5 min. 03 sec. / 7 min. 33 sec.	—
	Condition continued until the tool open-circuited, or flame appeared or 15 minutes expired	open-circuited	P
	Elements that opened in case an open circuit occurred .....	stator winding	P
	When flames appeared, immediately extinguished by CO <sub>2</sub> extinguisher		N/A
	Maximum leakage current measured throughout the abnormal test (mA) .....	See Table 13.1E	P
	Tool that did not operate after 15 min, cooled to room temperature and subjected to a 1500 V Electric Strength test (live parts and accessible parts)		P
	Tool that operated after 15 min, cooled to room temperature and subjected to a 2500 V Electric Strength test (live parts and accessible parts)		N/A

<b>19</b>	<b>MECHANICAL HAZARDS</b>		
19.1	Adequate protection against injury provided against moving and dangerous parts		P
	Protective enclosures, covers, and the like have adequate mechanical strength and cannot be removed without the aid of a tool		P
	No dangers from adjusting the guards		N/A
	No dangers due to movement or release of working elements during normal use		P
	No contact with dangerous moving parts using standard test finger (Fig 1)		P
A	Chuck keys so designed that they drop out of position when released		N/A
	Metal clips are not fixed to the flexible cable or cord		N/A
	The key fell out when inserted into the chuck, without tightening, and after the tool was turned such that the key was facing down		N/A
19.2	No sharp edges, burrs, flashes and the like		P
19.3	No contact of moving parts with test finger (Fig 1) with removal of dust collection system		P
19.4	Adequate grasping surfaces		P
19.5	Provision for visual checking of the contact of cutting tool with work piece		N/A

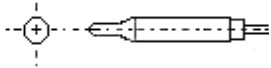
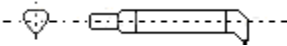
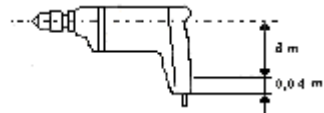
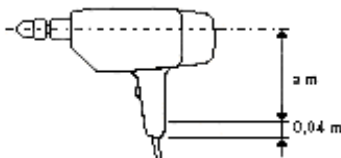
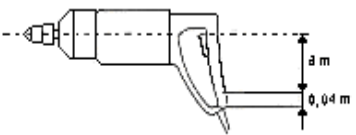
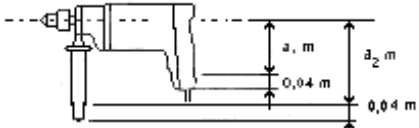
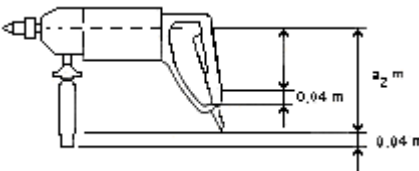
IEC 60745-2-1			
Clause	Requirement + Test	Result - Remark	Verdict
19.6	The no-load speed of the spindle did not exceed 110 % of the rated no-load speed		P
19.101	The force on the hand due to static stalling torque is not excessive		P
	Maximum measured static stalling torque or slip torque of the clutch ( $M_R$ ) .....	58,8 Nm	P
	The mean measured valued of the torque did not exceed the relevant maximum value in Figure 102 and Figure 103		P
	Single-hand support		
		$M_{Rmax} = 8 \text{ Nm}$ $M_{meas.} = \text{Nm}$	N/A
		$M_{Rmax} = 10 \text{ Nm}$ $M_{meas.} = \text{Nm}$	N/A
		$M_{Rmax} = (400 \times a) \text{ Nm}$ $M_{meas.} = \text{Nm}$	N/A
		$M_{Rmax} = (400 \times a) \text{ Nm}$ $M_{meas.} = \text{Nm}$	N/A
		$M_{Rmax} = (400 \times a) \text{ Nm}$ $M_{meas.} = \text{Nm}$	N/A
	Double-hand support		
		DM6P: $M_{Rmax} = 78 \text{ Nm}$ $M_{meas.} = 54,8 \text{ Nm}$	P
		DM6P: $M_{Rmax} = 78 \text{ Nm}$ $M_{meas.} = 58,8 \text{ Nm}$	P

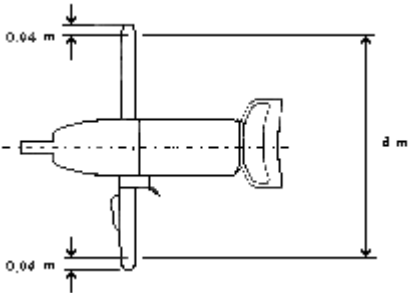
IEC 60745-2-1			
Clause	Requirement + Test	Result - Remark	Verdict
		$M_{Rmax} = (400 \times a) \text{ Nm}$ $M_{meas.} = \text{Nm}$	N/A

<b>20</b>	<b>MECHANICAL STRENGTH</b>		
20.1	Adequate mechanical strength in normal use		P
	No flashover or breakdown occurred after tests of 20.2-20.4 and 15..... :	See Table 15.2E	P
	No damage impairing compliance with this standard, and no live parts became accessible		P
20.2	Three blows applied to every weak point of enclosure by spring-operated impact test apparatus in Clause 5 of IEC 60068-2-75		P
	Brush cap impact energy (Nm) .....		—
	Other part impact energy (Nm)..... :	1,0 Nm	—
	Blows applied to protective devices, handles, levers, and knobs when necessary	Handle, enclosure, switch knob, air inlet	P
	No damage impairing compliance with standard		P
	No accessibility of live parts		P
	No cracks visible to naked eye		P
	Inner cover withstood test		N/A
20.3	Hand-held tool withstood impact of 3 varied drops on a concrete surface from 1 m		P
	No damage impairing compliance with standard		P
	No accessibility of live parts		P
	No cracks visible to naked eye		P
	Inner cover withstood test		N/A
20.4	Adequate mechanical strength of brush holder and their caps		N/A
	Brush cap removed and replace 10 times applying specified tightening torque		N/A
	Tightening torque (Nm)..... :		—
	No damage impairing compliance with standard		N/A
	No accessibility of live parts		N/A
	No cracks visible to naked eye		N/A
	No damage to threads		N/A

IEC 60745-2-1			
Clause	Requirement + Test	Result - Remark	Verdict
20.5	Handles and grasping surfaces have adequate mechanical strength to provide insulation between grasping area and output shaft		P
	A separate sample subjected to a single impact from 1m onto a concrete surface on each handle and each recommended grasping surface followed by an electric strength test of 1250 V a.c.		P
	No damage impairing compliance with standard		P
	No accessibility of live parts		P
	No cracks visible to naked eye		P
	No flashover or breakdown of insulation	See Table 15.2E	P

<b>21</b>	<b>CONSTRUCTION</b>		
21.1	Accidental changing of setting did not occur in tools with different voltages or different speed settings		P
21.2	Accidental changing of settings of control devices did not occur		P
21.3	Removal of parts ensuring required degree of protection against moisture not possible without aid of a tool		N/A
21.4	Fixing of handles, knobs and the like, used to indicate position of switches or similar components in a wrong position, was not possible		P
21.5	Replacement of a flexible cable or cord requiring displacement of a switch was possible without subjecting internal wiring to undue stress		P
	After repositioning of the switch and before reassembling the tool, verification of correct positioning of internal wiring was possible		P
21.6	Wood, cotton, silk, paper and similar fibrous or hygroscopic material not used as insulation, unless impregnated or chemically rendered non-fibrous		N/A
21.7	Asbestos not used		P
21.8	Ordinary driving belts not relied upon to ensure electrical insulation		N/A
	Special belt design employed to allow use as electrical insulation		N/A
21.9	Insulating barriers of Class II tools, and parts of Class II tools serving as supplementary or reinforced insulation are:		N/A
	- fixed such that they cannot be removed without being seriously damaged		N/A
	- so designed that they cannot be replaced in an incorrect position, and when omitted, the tool will be inoperable or manifestly incomplete		N/A

IEC 60745-2-1			
Clause	Requirement + Test	Result - Remark	Verdict
21.10	Use of the sheath (jacket) of a flexible cable or cord as supplementary insulation inside the tool is independent of mechanical and thermal stresses		N/A
21.11	No assembly gap with a width greater than 0.3 mm in supplementary insulation giving access to live parts		P
21.12	No hazards from parts of Class I tool such as wire, screw, nut, washer or spring becoming loose or falling out of position, and accessible metal not made live		P
	Clearance and creepage distances of Class II tool or class II construction not reduced to less than 50% of values shown in Table 10		N/A
	Class II tool or Class II construction, other than those of the all-insulated type, provided with an insulating barrier between accessible metal and motor parts and other live parts		N/A
	Class I tool with adequately fixed parts, barriers, and sufficiently large creepage and clearances		P
	All wires secured in place independent of terminal connection or solder		P
21.13	Supplementary and reinforced insulation not impaired by deposition of dirt, or dust resulting from wear of parts within the tool to the extent that creepage and clearances would be reduced		P
	Ceramic material not tightly sintered and similar materials, and beads alone, not used as supplementary or reinforced insulation		N/A
	Parts of natural or synthetic rubber used as supplementary insulation are resistant to aging		N/A
	Rubber parts so arranged and dimensioned that creepage distances not reduced below values in 28.1, even when cracks occurred		N/A
	Insulated material for embedded heating conductors serves only as basic insulation		N/A
	Aging test for rubber parts for 70 h at 100±2°C		N/A
	Rubber parts tested .....	-	—
21.14	Internal wiring, windings, and the like including insulation in general not exposed to oil, grease, and similar substances		P
	Adequate insulation properties of oil, grease, and similar substances used for lubrication of gears and the like with no effect on insulation		P
21.15	No access to brushes without aid of a tool		P
	When tightening screw-type brush-caps, two surfaces clamped together		N/A
	Locking device retaining brushes in position do not depend upon brush spring tension		P

IEC 60745-2-1			
Clause	Requirement + Test	Result - Remark	Verdict
	Screw-type brush-caps accessible from the outside of the tool made of or covered with insulating material of adequate strength, and not projecting beyond surrounding surface of the tool		N/A
	Properties of insulating materials		P
	– tested according to Cl. 20.2 and 20.4 for screw-type brush-caps accessible from outside of tool		N/A
	– tested as specified for supplementary insulation for class I and class III tools		N/A
	– tested as specified for reinforced insulation for class II tools		N/A
21.16	Tool employing a liquid system protects the user against increased risk of shock due to presence of liquid under normal use and faults of liquid system		P
	Tools employing liquid system constructed as Class III tools, or		N/A
	- class I or II and provided with a residual current device, and complying with 14.4-14.6, or		P
	- class I or class II and designed for use in combination with an isolating transformer and complying with 14.4 and 14.5		N/A
21.17	Accidental operation of switches and reset buttons on non-self-resetting controls did not occur when tool dragged across a horizontal surface		P
21.18	Tools, other than those provided with a flexible shaft, fitted with a mains switch which can be switched off by the user without releasing the grasp on the tool		P
	A switch locking in “on” position considered to meet the requirement of 21.18, provided it unlocks automatically when the trigger or actuating member is activated		P
A	The switch lock-on device is located outside the grasping area, or so designed that it is not likely to be unintentionally locked on by the user’s hand during intended left- or right-handed operation		P
	The switch with lock-on button in a recess within the grasping area cannot be actuated by a straight-edge utensil when the utensil is made to pass back and forth across the device in any direction		P
	The length of straight-edge utensil is sufficient to bridge the surface of the lock-on device and any surface adjacent to the lock-on device		P
21.18.1	Switch could not be locked in “on” position and did not remain in “on” position after trigger released when a risk with continued operation existed		N/A
21.18.2	Switch was locked in “off” position when a risk associated with inadvertent starting existed		N/A



IEC 60745-2-1			
Clause	Requirement + Test	Result - Remark	Verdict
21.19	Protection against electrical shock not affected when screws accessible from the outside replaced by longer screws simulating routine servicing		P
	Creepage and clearances not reduced below values in 28.1		P
21.20	Tool marked with the first numeral of IP system complies with IEC 60529..... :	-	N/A
21.21	No risk of electrical shock from charged capacitors when touching pins of the plug	Capacitor behind the switch	P
	Max. voltage measured between pins of the plug after one second after each disconnection (V) ..... :	-	N/A
	Line capacitors rated ... 0.1 $\mu$ F		N/A
21.22	Non-detachable parts secured reliably and withstood mechanical stress under normal use		P
	Snap-in devices have an obvious locked position and have fixing properties that do not deteriorate		N/A
	Parts disassembled and assembled 10 times prior to test showed no signs of deterioration		N/A
	Parts affected by temperature tested immediately after conditions of Clause 12		N/A
	All weak parts of the tool subjected to the 10 s push force of 50 N		N/A
	50 N pull force applied to cover or weak part when shaped prevented easy slippage of fingertips		N/A
	30 N pull force applied to cover or weak parts when projection of the gripped part was less than 10 mm in the direction of removal		N/A
	Test fingernail of Fig. 7 inserted in apertures and joints with a force of 10 N to enable a force of 30 N for 10 s by means of a loop while applying push/pull forces		N/A
	A torque of 2 Nm applied at the same time as pull or push force on parts 50 mm or smaller and likely to be subjected to twisting,		N/A
	A torque of 4 Nm applied at the same time as pull or push force on parts larger than 50 mm and likely to be subjected to twisting,		N/A
	Projection was less than 10 mm and required a torque of (Nm)..... :	-	N/A
	Parts not detached, and remained in locked position		N/A
21.23	Handles, knobs, etc., withstood axial force of 30 N for 1 minute		P
21.24	Storage hooks and similar devices for flexible cords are smooth and well rounded		N/A
21.25	Current-carrying parts and other parts resistant to corrosion under normal use		P

IEC 60745-2-1			
Clause	Requirement + Test	Result - Remark	Verdict
	After tests of Clause 30, no sign of corrosion on relevant parts		N/A
21.27	Insulation between SELV and other parts of non-class II tool meets requirements for double or reinforced insulation		N/A
21.28	Parts separated by protective impedance comply with requirements for double or reinforced insulation		N/A
21.30	Shafts of operating knobs, handles, levers, and the like not live, except when removal of such parts does not make the shaft accessible to test finger		N/A
21.31	Handles, levers, and knobs of non-class III tool held or actuated in normal use do not become live during an insulation fault		P
	Metallic handles, levers, and knobs with shaft and securing means likely to become live due to basic insulation fault, adequately covered by insulating material or their accessible parts separated from their shafts or securing means by insulation		N/A
	Covering or insulating material complies with Electric Strength test in Clause 15, Table 2, item 4		N/A
21.32	Tool likely to cut into concealed wiring or cord, has handles and grasping surfaces made of insulating material, or metal covered by insulating material, or their accessible parts are separated by insulating barrier(s) from accessible metal parts that may become live by the output shaft		P
	Insulated, stick type, auxiliary handle is provided with a flange — 12 mm high above grasping surface between grasping area and accessible parts that may become live by the output shaft		N/A
21.33	Capacitors in class II tools not connected to accessible metal parts, and their metallic casings are separated from accessible metal parts by supplementary insulation		N/A
	Capacitors tied to accessible metal parts comply with Clauses 9.1 and 21.36		N/A
21.34	Capacitors not connected between contacts of the thermal cut-outs		N/A
21.35	Lamp holders used only for connection of lamps		N/A
21.36	Protective impedance consists of at least two separate components with impedance unlikely to change significantly during lifetime of tool		N/A
	When a component short or open-circuited, values in Clause 9.1 were not exceeded		N/A
	Resistors comply with 14.1 of IEC 60065 and capacitors comply with 14.2 of IEC 60065		N/A
21.37	Air-intake ventilation openings not excessively large		P

IEC 60745-2-1			
Clause	Requirement + Test	Result - Remark	Verdict
	It was not possible to insert a steel ball 6 mm in diameter through air-intake openings other than those adjacent to fan		P

22	<b>INTERNAL WIRING</b>		
22.1	Wireways smooth and free from sharp edges, burrs, etc.		P
	Holes in metal through which insulated wires pass provided with bushings or, except as required by relevant part 2, have smooth, well-rounded edges with a radius of 1,5 mm		P
	Wiring prevented from coming into contact with moving parts		P
22.2	Internal wiring and electrical connections adequately protected or enclosed		P
22.3	Internal wiring adequately rigid, fixed or insulated such that, in normal use, creepage and clearances cannot be reduced below values in 28.1		P
	The insulation not damaged in normal use		P
	Insulation of internal wiring electrically equivalent to insulation of cords complying with IEC 60227 or IEC 60245		N/A
	No breakdown resulted upon application of a 2000 V electric voltage for 15 min between conductor and metal foil wrapped around insulation		P
	Sleeves used as supplementary insulation on internal wiring remain in position by clamps at both ends requiring its removal by breaking or cutting		N/A
22.4	Use of green/yellow conductors for earthing terminals only		P
22.5	Aluminium wires not used for internal wiring		P
22.6	Stranded conductors with lead-tin soldering are only used with spring terminals with constant contact pressure, except when clamping means pose no risk of bad contact		N/A

23	<b>COMPONENTS</b>		
23.1	Components comply with relevant IEC standards	See appended Table 23.1	P
	Components used in accordance with their markings		N/A
	Applied exceptions..... :		N/A
23.1.1	Capacitors in auxiliary windings of motors marked with their rated voltage and rated capacitance		N/A
23.1.2	Fixed capacitors for radio interference suppression comply with IEC 60384-14		P

IEC 60745-2-1			
Clause	Requirement + Test	Result - Remark	Verdict
23.1.3	Small lamp holders similar to E10 lamp holders meet requirements for E10 lamp holders		N/A
23.1.4	Insulating and safety insulating transformers comply with IEC 61558-1		N/A
23.1.5	Appliance couplers other than those used for IPX0 tools comply with IEC 60309, and those used for IPX0 comply with IEC 60320		N/A
	Instructions provided to inform user to connect the tool with non-IEC appliance couplers		N/A
23.1.6	Automatic controls not complying with IEC 60730-1 tested according to this standard, and additionally according to 11.3.5 – 11.3.8 and 17 of IEC 60730-1		N/A
	IEC 60730-1 tests conducted under conditions occurring in the tool		N/A
	Type of controls used and number of operations completed per Cl. 17 of IEC 60730-1 (cycles).....:	-	N/A
	Correct markings used on automatic controls		N/A
	Tests of Clause 17 of IEC 60730-1 were not conducted on automatic controls because tool complies with this standard when protective device short-circuited		N/A
	Thermostats and temperature limiters tested in accordance with a specific exception in footnote b) of Table 1 of Clause 12		N/A
23.1.7	Unless otherwise specified, tests on components per other standards conducted separately according to the relevant standard		N/A
	Component, marked and used per its markings		N/A
	Components not mentioned in Table 1 of Clause 12 tested as part of the tool		N/A
23.1.8	If no IEC standard, or when component not marked or used not as marked, component tested under conditions occurring in the tool, and number of samples as required by similar specifications		N/A
23.1.9	Capacitor voltage did not exceed 1.1 times its rated voltage (V).....:	-	N/A
23.1.10	Adequate breaking capacity of mains switches with no electrical mechanical failure		P
	Mains switches rated for min. 50K cycles of operations	5E4	P
	Switch operated 50 times with motor stalled		P
	For electronic control device switching off before opening the main contacts, switch operated five times with the electronic device short-circuited		N/A

IEC 60745-2-1			
Clause	Requirement + Test	Result - Remark	Verdict
23.1.11	Switches, not separately tested and found to comply with IEC 61058-1 under the conditions occurring in the tool, comply with Annex I		N/A
	Test of 17.2.4.4 of IEC 61058-1 conducted for a min. of 50000 cycles of operation .....		N/A
	Switches operated only with the aid of a tool and intended for no load operation were not subjected to tests of Clause 17 of IEC 61058-1		N/A
	The above also applied to switches operated by hand and interlocked not to be operated under load		N/A
	Switches without interlock tested per IEC 61058-1, 17.2.4.4 for a min. of 100 cycles of operation.....		N/A
	Tests of 17.2.4.4 of IEC 61058-1 not conducted on a switch when tool met the requirements of this standard when the switch short-circuited		N/A
23.2	Tool not fitted with switches or automatic controls in flexible cords		N/A
	Tool not fitted with devices causing the protection device in the fixed wiring to operate		N/A
	Tool not fitted with thermal cut-outs which can be reset by a soldering operation		N/A
23.3	R Overload protection devices of the non-self-resetting type or		N/A
	the tool is equipped with a momentary switch with no provision for being locked in the "on" position		N/A
23.4	Plugs and socket-outlets used as terminal devices for heating elements and plugs and socket-outlets for ELV circuits not interchangeable with plugs and socket-outlets in IEC 60884, and with connectors and tool inlets complying with IEC 60320		N/A
23.5	Motors connected to the supply mains with insulation inadequate for the rated voltage comply with Annex B		N/A

24	SUPPLY CONNECTION AND EXTERNAL FLEXIBLE CORDS		
24.1	Tool rated in voltage or frequency for connection to public supplies provided with a supply cord with a plug		P
	Tool intended to be connection to non-public power supplies provided with a supply cord without a plug		N/A
	Tool provided with appliance inlet for connection to a supply having at least same degree of protection against moisture as required for the tool, and with locking device preventing accidental disconnection		N/A
	Tool provided with a supply cord for connection to a supply $\leq 0.5$ m and fixed with an in-line connector (cable coupler) and its mating counterpart		N/A

IEC 60745-2-1			
Clause	Requirement + Test	Result - Remark	Verdict
	The in-line connector provided with at least the same degree of protection against moisture as required for the tool		N/A
	Locking devices complied with pull test of 24.14		N/A
24.2	Supply cord assembled to the tool by attachment type (specify X, Y, or Z) .....	Type Y attachment	P
	Supply cord with type X and type Y attachment is ordinary flexible cord or a special cord only available from the manufacturer or its agent		P
	Special cord includes part of the tool		N/A
24.3	Plugs fitted with only one flexible cord		P
24.4	Supply cord not lighter than ordinary tough rubber sheathed flexible cord or ordinary PVC sheathed flexible cord		P
	PVC cords not used if external metal parts exceed 75 K temperature rise		N/A
	Power supply cords of single-phase tool with a plug and rated current $\leq 16$ A supplied with a plug complying with IEC 60884 or IEC 60309		P
	Class I tools fitted with plugs complying with IEC 60309, Sheet 2-1		P
	Class II tools fitted with plugs complying with IEC 60309, Sheet 2		N/A
	Class III tools fitted with plugs complying with IEC 60309, Sheet 2-1		N/A
	Body of plug covered with, rubber, polyvinyl chloride, or a material with equivalent mechanical strength		P
	Supply cords of class I, single-phase tool rated $> 16$ A $\leq 63$ A, and multi-phase tool rated $\leq 63$ A, provided with a plug complying with IEC 60309 and standard Sheet 2-III based on current		N/A
	Supply cords of class II, single-phase tool rated $> 16$ A $\leq 63$ A, and multi-phase tool rated $\leq 63$ A, provided with a plug complying with IEC 60309 and standard Sheet 2		N/A
	Supply cords of class III, single-phase tool rated $> 16$ A $\leq 63$ A, and multi-phase tool rated $\leq 63$ A, provide with a plug complying with IEC 60309 and standard Sheet 2-III		N/A
24.5	Nominal cross-section area of supply cord per Table 6 (mm <sup>2</sup> )..... :	220-240 V: 1,0 mm <sup>2</sup> 110-120 V: 1,5 mm <sup>2</sup>	P
24.6	Supply cord of class I tool has green/yellow core connected to internal earthing terminal of the tool, and to earthing contact of plug		P

IEC 60745-2-1			
Clause	Requirement + Test	Result - Remark	Verdict
24.7	Lead-tin solder not used to consolidate leads under pressure, except when clamping means used prevent risk of a bad contact		N/A
	Clamping screws alone not used for securing soldered leads		N/A
24.8	Moulding supply cord to any part has no effect on the insulation of the cord		N/A
24.9	Inlet openings provided with a bushing, or no risk of damaging protective covering of supply cord		P
24.10	Inlet bushings shaped to prevent damage to supply cord		P
	Inlet bushings reliably fixed and not removable without the aid of a tool		P
24.12	Cord guards provided with adequate mechanical strength and retain these properties throughout extended normal use		P
	Flexing test performed in apparatus shown in Fig. 9		P
	Weight attached to cable or cord (kg) ..... :	6 kg	—
	Oscillating member moved backwards and forwards through an angle of 90° (45° on either side of the vertical) with rate of flexings 60/minute		P
	After 10,000 flexings, sample turned through 90° about the centre of the cord guard		P
	After the test, cord guard not loosened, and no damage to cord guard and flexible cable impairing compliance with this standard		P
	Number of strands versus number of broken strands of each conductor not more than 10%	0%	P
	Cord guard did not slip out from its location after completion of ten 1 sec lifts		P
24.13	Cord guard of insulating material provided to protect against excessive bending at inlet opening		P
	Guard fixed reliably and projects outside tool a distance beyond inlet opening of at least 5 times the overall diameter of cable or cord		P
	Cord guard integral to tool minimum 100 mm longer than guard		P
	Mass attached to the free end of cable or cord (g) . :	681 g	—
	Temperature sensitive cord guard tested at 23±2°C		N/A
	Curvature of cable or cord is nowhere less than 1.5 of external diameter of cable		P
24.14	Conductors relieved from strain, twisting and protected from abrasion		P
	It is not possible to push the cord into the tool		P

IEC 60745-2-1			
Clause	Requirement + Test	Result - Remark	Verdict
	Pull force was applied 25 times at the force prescribed in Table 7 (N) .....	100 N	—
	After pull test, cord, other than automatic cord reel, subjected to torque in Table 7 for 1 min (Nm) .....	0,35 Nm	P
	The cord was not damaged during the tests		P
	Cord longitudinal displacement (mm) .....	0 mm	P
	Conductors movement in the terminals (mm).....	0 mm	P
	No appreciable strain at the connection		P
	Creepage and clearances not reduced below values in Cl. 28.1		P
24.15	Cord anchorage either accessible only with the aid of a tool, or the cord can only be fitted using a tool		P
24.16	Cord anchorage for type X attachment		N/A
	Cord anchorage allows easy replacement of cord		N/A
	It is evident how strain relief and prevention of twisting are accomplished by the cord anchorage		N/A
	Anchorage is suitable for different types of cord, or tool designed to be fitted with only one type of cord		N/A
	Cord anchorage screws separated by supplementary insulation		N/A
	Cord is not clamped by metal screw bearing directly on the cord		N/A
	At least one part of cord anchorage securely fixed to the tool, unless it is part of the specially prepared cord		N/A
	Screws intended to fix the cord in place are not used to secure any other part, or it is clear the tool is inoperative		N/A
	Parts fastened to the cord anchorage by the same screw could not be removed without the aid of a tool		N/A
	Cord anchorage is such that in case of labyrinths, the labyrinths cannot be bypassed in a way that the requirement of Clause 24.14 is not met		N/A
	For type X attachment, gland not used as cord anchorage for power supply cord		N/A
	Cord anchorage in class I tool is of insulating material or provided with an insulating lining		N/A
	Cord anchorage in class II tool is of insulating material, and when metallic, meet requirements for supplementary insulation		N/A
	Type X has one or more nuts to secure cord anchorage to tool		N/A
	Clamping member complies with Figure 6		N/A



IEC 60745-2-1			
Clause	Requirement + Test	Result - Remark	Verdict
	Tests of Cl. 24.14 conducted with lightest type of cord of smallest cross-section and next heavier type as in Cl. 25.2 (sizes, mm <sup>2</sup> )..... :	-	N/A
	Specially prepared cord tested with the cord as delivered		N/A
	Conductors inserted into terminals, terminal screws tightened sufficiently to prevent conductors from easily changing their position, torque set at ..... :	-	N/A
24.17	Adequate cord anchorages are provided for type Y and Z attachments and complied with 24.14		P
24.18	Knots and tying strings for type X attachment are not used		N/A
24.19	The insulated conductors of the supply cord are insulated from accessible metal parts by basic insulation for class I tool, and supplementary insulation for class II tools		P
	- insulation consists of a separate insulating lining fixed to cord anchorage		P
	- a sleeve or grommet is fixed to the cord		N/A
	- for class I tools, insulation consists of sheath of the sheathed cord		P
24.20	For type X attachment space for supply cables or supply cord provided inside or as a part of tool		N/A
	- space permits verification of correct connection and positioning of conductors		N/A
	- space permits covers to be fitted without risk of damage to supply conductors or their insulation		N/A
	- uninsulated end of conductor, when detached from a terminal, cannot come into contact with accessible metal parts		N/A
	Installation test conducted with cables or flexible cords of the largest cross-sectional area as per Clause 25.2 (mm <sup>2</sup> )..... :	-	N/A
	For pillar terminals (with conductors that are not separately clamped 30 mm or less from terminal), and for other terminals with screw clamping, a force of 2 N applied to the wire in any direction and adjacent to the terminal, screw or stud		N/A
	The uninsulated end of the conductor did not come into contact with accessible metal parts		N/A
24.21	Appliance inlet has no accessible live parts		N/A
	- appliance inlet allows easy insertion of connector		N/A
	- after insertion of connector, tool not supported by the connector during any position of normal use on a flat surface		N/A

IEC 60745-2-1			
Clause	Requirement + Test	Result - Remark	Verdict
	Standard test finger applied for tool inlet other than appliance inlet per IEC 60320		N/A
	Appliance inlet complies with IEC 60320		N/A

<b>25</b>	<b>TERMINALS FOR EXTERNAL CONDUCTORS</b>		
25.1	Type X attachment, other than specially prepared cord, provided with terminal connections made by screws, nuts, or equally effective devices		N/A
	Use of screw-type terminals per IEC 60998-2-1		N/A
	Use of screwless-type terminals per IEC 60998-2-2		N/A
	Use of clamping units according to IEC 60999-1 considered equally effective devices		N/A
	Screws and nuts do not fix other components		P
	Screws and nuts allowed to also clamp internal conductors when they are unlikely to be displaced when fitting supply conductors		N/A
	For tool with type X attachment, soldered connections allowed to be used for connection of external conductors, when soldering alone is not used to maintain conductor in position		N/A
	When provided, barriers prevent creepages and clearances between live parts and other metal parts from being reduced to < 50% of values in 28.1, the conductor can be fixed by soldering alone		N/A
	For type Y and Z attachments, soldered, welded, crimped and similar connections allowed for the connection of external conductors		P
	Class II tools, conductor so positioned or fixed that soldering, crimping, or welding alone not relied upon to maintain the conductor in the position		N/A
	Barriers prevent creepages and clearances between live parts and other metal parts from being reduced to < 50% of values in 28.1 for the Class of tool using Type Y or Z attachments		N/A
	Conductors connected by soldering are held in place near termination independent of solder		N/A
	Conductor is "hooked in" before soldering and the hole through which it passes is not too large		N/A
	Terminals of a component built into the tool used to secure external conductors		P
	Leads additionally fixed near terminations		N/A
	Stranded conductors secured at insulation and conductor		P
25.2	Terminals for type X attachment fitted with special connection or accommodate nominal cross-sectional areas as in Table 8		N/A

IEC 60745-2-1			
Clause	Requirement + Test	Result - Remark	Verdict
	Cables or cords of the specified smallest and largest cross-sectional areas can be fitted (mm <sup>2</sup> )..... :		N/A
	Supply cord terminals withstood pull force of 5 N		N/A
25.3	For type X attachment, when clamping means tightened or loosened, terminal did not loosen up, no stress on internal wiring, and creepage and clearances not reduced		N/A
	Torque applied per IEC 60999-1, Clause 9.6 at 2/3 torque of that in Table 4 of IEC 60999-1 (Nm) ..... :	-	N/A
	Terminals secured by two screws to prevent loosening		N/A
	Correct position of supply terminals maintained by switches and similar devices with recesses and verified after connection of supply cable and repositioning of device		N/A
	Sealing compound without other means of locking not used		N/A
	Self-hardening resins used only on terminals that are not subject to torsion in normal use		N/A
25.4	Type X attachment using terminals to clamp the conductor between metal surfaces do so without damage to conductor after torque test per Cl. 25.3		N/A
25.5	Type X attachments which require no special preparation of conductor for correct connection, and conductor does not slip out when clamping screws or nuts tightened		N/A
	Type X specially prepared cord used		N/A
	There were no deep or sharp indentations on the conductors after torque test per Clause 25.3		N/A
25.6	End of conductor inserted in the hole of pillar type terminals is visible, or can pass beyond threaded hole for a distance of half nominal diameter of screw, or 2.5 mm, the greater of the two (mm) ..... :		N/A
25.7	For type X attachment, terminals clearly recognizable and accessible after opening the tool		N/A
	All terminals located behind one cover, or one part of the enclosure		P
25.8	Terminal devices not accessible without the aid of a tool		P
25.9	For tool with type X attachment, terminal devices located or shielded to prevent a strand of wire from escaping		N/A
	In case of class II tool, live parts and metal parts separated from accessible metal parts by supplementary insulation		N/A
	8 mm long free wire of the stranded supply conductor did not touch any accessible metal part		N/A

IEC 60745-2-1			
Clause	Requirement + Test	Result - Remark	Verdict
	8 mm long free wire of stranded conductor connected to an earthing terminal did not touch any live part		N/A

26	PROVISION FOR EARTHING		
26.1	Accessible metal parts of class I tool permanently connected to an earthing terminal or termination within the tool		P
	Accessible metal parts of class I tool permanently connected to the earthing contact of the tool inlet		N/A
	Printed circuit boards are not used to provide continuity of protective earthing circuit		P
	No electrical connection between earthing terminals or contacts and neutral terminal		P
	No provisions for earthing in Class II and III tools		N/A
	Metal parts behind a decorative cover that do not withstand test of Clause 20 considered accessible metal parts		N/A
26.2	Clamping means of earthing terminals adequately locked against accidental loosening		P
	Earthing connections not possible to loosen without the aid of a tool		P
	Terminals with screw clamping comply with the relevant requirements of Clause 25, and screwless terminals comply with IEC 60998-2-2		N/A
	For specially prepared cords, terminals comply with IEC 60760		P
	Screwless terminals tested per IEC 60998-2-2		N/A
26.3	Earth connection of detachable parts was made before the current-carrying connections established when placing the part in position, and the current carrying connections separated before earth connection was broken when removing the part		N/A
	If cord slips out of cord anchorage, current-carrying conductors become taut before earthing conductor		P
26.4	No risk of corrosion between metal parts of earthing terminals and copper of earthing conductor		N/A
	Parts transmitting current in case of an insulation fault, other than parts of metal frame or enclosure, are coated or uncoated metal with adequate resistance to corrosion		N/A
	Thickness of electroplated coating ( $\mu\text{m}$ ) .....	-	N/A
	Parts of coated or uncoated metal providing or transmitting contact pressure only, adequately protected against rusting		N/A

IEC 60745-2-1			
Clause	Requirement + Test	Result - Remark	Verdict
	Protection provided against risk of corrosion resulting from contact between copper and aluminium (or aluminium alloy)		N/A
	Parts subjected to a treatment such as chromate conversion coating are used only to provide or transmit contact pressure		N/A
	Thickness of coating of steel measured in accordance with ISO 2178 or ISO 1463 ( $\mu\text{m}$ )..... :	-	N/A
	Resistance to rusting test .....	See also Clause 30	N/A
26.5	Resistance of earthing circuit (max. 0.1 $\Omega$ )..... :	0,024	P
	Test current (A) .....	25	—
	Voltage drop between the earthing terminal and accessible metal part (V) .....	12	—

<b>27 SCREWS AND CONNECTIONS</b>			
27.1	Fixings and electrical connections (includes earthing connections) withstood mechanical stresses occurring in normal use		P
	Screws not made of soft metal such as zinc or aluminium		P
	Diameter of screws of insulation material (mm). .... :	-	N/A
	Screws transmitting electrical contact pressure screw into metal		P
	Screws made from insulating material are not used if their replacement by a metal screw could impair supplementary or reinforced insulation		P
	Screws removed when replacing the supply cord with type X attachment, or during maintenance, are not of insulating material where their replacement by a metal screw could impair basic insulation		N/A
	Screws and nuts tightened and loosened 10 times for screw engaged with a thread of insulating material		P
	Nuts and other screws tightened and loosened five times		P
	Screws engaging with a thread of insulating material completely removed and reinserted each time		P
	When testing terminal screws and nuts, a flexible conductor of the largest cross-sectional area per Clause 25.2 placed in the terminal ( $\text{mm}^2$ )..... :	1,5 $\text{mm}^2$	P
	Torque per column I of Table 9 applied to metal screw without head (Nm)..... :	-	N/A

IEC 60745-2-1			
Clause	Requirement + Test	Result - Remark	Verdict
	Torque per column II of Table 9 applied to other metal screws and nuts (Nm)..... :	1. 1,2 Nm, grip screws 2. 1,2 Nm, anchorage screws 3. 0,8 Nm, terminal screw 4. 1,2 Nm, earthing terminal	P
	Torque per column II of Table 9 applied to screws of insulating material, having a hexagonal head with dimension across flats exceeding the overall thread diameter (Nm) ..... :		N/A
	Torque (column II, Table 9) applied to screws of insulating material, with cylindrical head and a socket for a key, having cross-corner dimension exceeding overall thread diameter (Nm)..... :		N/A
	Torque per column II of Table 9 applied to screws of insulating material, with a head having a slot or cross slots, the length of which exceeds 1.5 times the overall thread diameter (Nm)..... :		N/A
	Torque per column III of Table 9 applied to other screws of insulating material (Nm) ..... :		N/A
	Conductor moved each time the screw or nut was loosened		P
	No damage impairing further use of fixing or electrical connections		P
27.2	Contact pressure not transmitted through insulating material other than ceramic, unless compensated for shrinkage or distortion		N/A
27.3	Space-threaded screws not used for connection of current-carrying parts		P
	No thread-cutting screws used for connection of current-carrying parts		N/A
	Use of two space-threaded or thread-cutting screws in earthing circuits		N/A
27.4	Screws making both mechanical and electrical connections are locked against loosening		N/A
	Rivets for current-carrying connections subjected to torsion in normal use locked against loosening		N/A

<b>28</b>	<b>CREEPAGE DISTANCES, CLEARANCES AND DISTANCES THROUGH INSULATION</b>		
28.1	Creepage and clearances not less than the values in Table 10, except for cross-over points of motor windings ..... :	See appended Table 28.1	P
	When a resonance voltage occurs, creepage and clearance are not less than specified for the voltage imposed by the resonance; these values increased by 4 mm in case of reinforced insulation		N/A

IEC 60745-2-1			
Clause	Requirement + Test	Result - Remark	Verdict
	Creepage and clearances for a tool with an appliance inlet measured with an appropriate connector inserted		N/A
	Creepage and clearances on tools with Type X attachment measured with supply conductor of largest cross-section per Clause 25.2 (mm <sup>2</sup> )..... :	-	N/A
	Measurements repeated without the conductors		N/A
	Creepage and clearances on a tool with other attachment measured on the "as delivered" tool		P
	Measurements on tool with belt made with the belt in place and belt tension adjusted to the most unfavourable position within its adjustment range		N/A
	Measurements repeated with the belt removed		N/A
	Movable parts placed in the most unfavourable position; nuts and screws with non-circular heads tightened in the most unfavourable position		P
	Clearances between terminals and accessible metal parts also measured with screws and nuts unscrewed as far as possible and they were not less than 50% of Table 10 .....	See Table appended 28.1	P
	Distances through slots or openings in external parts of insulating material measured to metal foil in contact with accessible surface with the foil pushed into corners using standard test finger .....	See appended Table 28.1	P
	2 N force applied by test finger to bare conductors and uninsulated capillary tubes of thermostats and similar devices while measurement made		P
	30 N force applied by test finger to enclosure		P
	Measurements made according to Annex A	See appended Table 28.1	P
	Creepage on an interposed barrier consisting of two parts not cemented together also measured through the joint		N/A
	Clearances on an interposed barrier measured over the barrier or, when barrier consisted of two parts with mating surfaces not cemented together, through the joint.	See appended Table 28.1	N/A
	Creepage and clearances on a tool having parts with double insulation and no metal between basic insulation and supplementary insulation		P
	PWB with peak voltage stresses $\leq 150$ V per mm between parts of different potential provided with a min. distance of 0.2 mm, when protected against deposition of dirt	See appended Table 28.1	N/A
	-PWB with 100 V per mm provided with a min. distance of 0.5 mm, when not protected against deposition of dirt	See appended Table 28.1	N/A

IEC 60745-2-1			
Clause	Requirement + Test	Result - Remark	Verdict
	Values of the table applied when limits mentioned above resulted in higher values than in the table	See appended Table 28.1	N/A
	Reduced creepage distances applied for peak voltages ... 50 V if Proof Tracking Index (PTI) of PWB, per Annex G, greater than 175 (PTI)..... :	See appended Table 28.1	N/A
	Distances reduced further since the tool complied with the requirements of Clause 18 distances short-circuited one at a time..... :	See appended Table 28.1	N/A
	Creepage and clearances within optocouplers not measured when individual insulation adequately sealed, with air excluded between material layers		N/A
	For live parts of different polarity separated by basic insulation only, creepage and clearances reduced as tool complied with Clause 18 when creepage and clearances short-circuited..... :	See appended Table 28.1	N/A
28.2	Distance through insulation between metal parts was —1.0 mm for working voltages ... 130 V when separated by supplementary insulation	See appended Table 28.2	N/A
	Distance through insulation between metal parts was —1.5 mm for working voltages ... 130 V when separated by reinforced insulation	See appended Table 28.2	N/A
	Distance through the insulation was — 1.0 mm for reinforced insulation used between windings and accessible metal	See appended Table 28.2	N/A
	Distance through insulation between metal parts was —1.0 mm for working voltages > 130V ... 250V when separated by supplementary insulation, and —2.0 mm when separated by reinforced insulation	See appended Table 28.2	P
	– requirement waived as insulation applied was in thin sheet form, other than mica or similar, and for supplementary insulation consisting of at least two layers, one layer having withstood electrical strength test for supplementary insulation		N/A
	– requirement waived as insulation applied was of at least three layers and for reinforced insulation, two layers in contact having withstood the electric strength test for reinforced insulation		N/A
	– requirement waived as max. temperature rise determined during test of Cl. 12 did not exceed values in 12.5 for inaccessible supplementary or reinforced insulation		N/A
	–requirement waived as inaccessible reinforced or supplementary insulation, after conditioning for 168h at temperature 50 K greater than max rise determined per Cl. 12, withstood an electric strength test per Cl. 15 at the oven temperature and room temperature (°C) .....		N/A



IEC 60745-2-1			
Clause	Requirement + Test	Result - Remark	Verdict
	For optocouplers, 168 h of conditioning at 50 K higher than the max. temperature rise measured on optocouplers during tests of Clauses 12 and 18, while operating under most difficult conditions		N/A

29	<b>RESISTANCE TO HEAT, FIRE AND TRACKING</b>		
29.1	External parts of non-metallic material, insulating material supporting live parts, connections and thermoplastics providing supplementary or reinforced insulation sufficiently resistant to heat		P
	Relevant parts subjected to ball-pressure test subsequent to a 24 h exposure to 15 °C-35 °C, and a relative humidity between 45 % and 75 %	See Table 29.1	P
	For coil formers, parts supporting or retaining terminals in position subjected to test .....	See Table 29.1	N/A
29.2	Part of non-metallic material, except for decorative trims, knobs, and other parts not likely to be ignited or propagate flames originating from inside the tool, are resistant to ignition and spread of fire		P
	Parts of non-metallic material other than material classified at least HB40 per IEC 60695-11-10, provided test sample not thicker than relevant part, comply with glow-wire test of IEC 60695-2-11:	See Table 29.2	N/A
	Soft, foamy, and similar materials which cannot be subjected to glow wire test complied with ISO 9772 for category HBF material with test sample not thicker than relevant part		N/A
29.3	Insulating materials resistant to tracking		N/A
	Proof tracking test of Annex G conducted on insulating materials used under severe or extra-severe duty conditions:	See Table 29.3A	N/A
	For parts of insulating material used under severe duty conditions, test voltage was 175 V		N/A
	When specimens did not withstand above test and there was no hazard other than fire, surrounding parts subjected to needle-flame test of Annex F .....	See Table 29.3B	N/A
	For parts of insulating material used under extra-severe duty conditions, test voltage was 250 V		N/A
	When specimens did not withstand above test, but withstood test conducted at 175 V, and there was no hazard other than fire, surrounding parts subjected to needle-flame test of Annex F .....	See Table 29.3B	N/A
	Needle-flame test on all parts of non-metallic material positioned within a distance of 50 mm from any place where a tracking path may occur		N/A
	A separate barrier or enclosure shielding parts from the tracking path, subjected to needle-flame test		N/A

IEC 60745-2-1			
Clause	Requirement + Test	Result - Remark	Verdict
<b>30</b>	<b>RESISTANCE TO RUSTING</b>		
30.1	Ferrous parts adequately protected against rusting		N/A
	Parts subjected to test ..... :	-	—
	All grease removed from the parts to be tested by immersing them in a degreasing agent for 10 min		N/A
	Parts were immersed for 10 min in a 10 % solution of ammonium chloride in water at $(20 \pm 5) ^\circ\text{C}$		N/A
	Without drying, all drops shook off, and parts placed for 10 min in a box containing air saturated with moisture at $(20 \pm 5) ^\circ\text{C}$		N/A
	After parts dried for 10 min in a heating cabinet at $(100 \pm 5) ^\circ\text{C}$ , no evidence of rust on surfaces		N/A
	Small helical springs and the like and parts exposed to abrasion covered by a layer of grease		N/A
<b>31</b>	<b>RADIATION, TOXICITY, AND SIMILAR HAZARDS</b>		
31.1	Tool did not emit harmful radiation, present a toxic or similar hazard	See Part 2 for particular requirements	N/A
31.2	Tool fitted with a laser of category II or lower, according to IEC 60825-1		N/A
<b>ANNEX B</b>	<b>MOTORS NOT ISOLATED FROM THE SUPPLY MAINS AND HAVING BASIC INSULATION NOT DESIGNED FOR THE RATED VOLTAGE OF THE TOOL</b>		N/A
<b>ANNEX F</b>	<b>NEEDLE-FLAME TEST</b>		N/A
<b>ANNEX G</b>	<b>PROOF TRACKING TEST</b>		N/A
<b>ANNEX I</b>	<b>SWITCHES</b>		N/A
<b>ANNEX K</b>	<b>BATTERY TOOLS AND BATTERY PACKS</b>		N/A
<b>ANNEX L</b>	<b>BATTERY TOOLS AND BATTERY PACKS PROVIDED WITH MAINS CONNECTION OR NON-ISOLATED SOURCES</b>		N/A
<b>ANNEX M</b>	<b>SAFETY OF WORKING STANDS FOR OPERATION WITH HAND-HELD MOTOR-OPERATED ELECTRIC TOOLS</b>		N/A

9.1	TABLE: Protection against access to live parts				N/A
Measurement between relevant parts and poles of supply source	Rated voltage U (V)	Measured voltage (V)	Measured current (A)	Measured capacitance (µF)	
Supplementary information:					

11.1	TABLE: Input data under no load conditions						P
Rated voltage U(V)				Rated input (W) or current I (A)	Measured input (W) or current (A)	Deviation	Load condition / Remarks
Single Voltage (V)	Lower Voltage Limit (V)	Upper Voltage Limit (V)	Mean Value of Range				
-	110	120	115	1700 W	852 W	200 %	No load (DM6P)
-	220	240	230	2000 W	880 W	227 %	No load (DM6P)
-	110	120	115	1700 W	819 W	207 %	No load (DM62)
-	220	240	230	2000 W	821 W	243 %	No load (DM62)
Supplementary information: Optional: Locked Rotor Current _____ Amps							

12.1 A	TABLE: Temperature Rise Measurements (110-120 version)		P
Test voltage .....	103 V / 110 V / 120 V / 127 V		—
Ambient temperature (°C) .....	22,4 °C / 23,5 °C / 23,9 °C / 23,8 °C		—
Operating time .....	Continuous operation till steady condition		—
No Load Speed .....	573/ 621/ 684/ 728 /min		—
Input current (A) / Input Wattage (W) .....	18,0/ 18,2/ 18,6/ 18,8 A 1774 /1924 /2128/ 2280 W		—
Torque (Nm) .....	16,6 Nm		—
Measurement at:	Temperature rise in °C	Allowed Limit	
Ambient of switch	19	30	
Supply cord	34	50	
Internal wire near motor	10	50	
Support of PCB	5	50	
Handle	8	50	
Switch knob	3	50	
Enclosure	28	60	
Motor core	28	Ref.	
Supplementary Information: Note: See Table 13.1A for Leakage Current Test after Temperature Test Note: The heating test was under rated input 230 V; 2000 W which is more severe.			

12.3 A	TABLE: Temperature Rise of Windings (110-120 V version)					P
Part under test (windings and core laminations)	R <sub>1</sub> (Ω)	R <sub>2</sub> (Ω)	dT (K) by resistance	Allowed dT (K)	Insulation Class	
Stator (1)	0,1264	0,1623	78,1	140	Class 180	
Stator (2)	0,1241	0,1615	77,8	140	Class 180	
Rotor (1-5 <sup>th</sup> bar)	0,1461	0,1881	74,2	140	Class 180	
Supplementary Information: Note: See Table 13.1A for Leakage Current Test after Temperature Test						

12.1 B	TABLE: Temperature Rise Measurements (220-240 version)		P
Test voltage .....	207 V / 220 V / 240 V / <b>254 V</b>		—
Ambient temperature (°C) .....	20,5 °C / 20,5 °C / 21,0 °C / 21,5 °C		—
Operating time .....	Continuous operation till steady condition		—
No Load Speed .....	561/ 603/ 666/ 709 /min		—
Input current (A) / Input Wattage (W) .....	9,04/ 9,12/ 9,26/ 9,38 A 1762/ 1898/ 2106/ 2260 W		—
Torque (Nm) .....	18,9 Nm		—
Measurement at:	Temperature rise in °C	Allowed Limit	
Ambient of switch	18	30	
Supply cord	33	50	
Internal wire near motor	13	50	
Support of PCB	5	50	
Handle	7	50	
Switch knob	3	50	
Enclosure	27	60	
Motor core	26	Ref.	
Supplementary Information: Note: See Table 13.1A for Leakage Current Test after Temperature Test			

<b>12.3 B</b>	<b>TABLE: Temperature Rise of Windings (220-240 V version)</b>					<b>P</b>
Part under test (windings and core laminations)	R <sub>1</sub> (Ω)	R <sub>2</sub> (Ω)	dT (K) by resistance	Allowed dT (K)	Insulation Class	
Stator (1)	0,4580	0,5588	56,2	140	Class 180	
Stator (2)	0,4577	0,5583	56,2	140	Class 180	
Rotor (1-9 <sup>th</sup> bar)	0,9459	1,2673	86,8	140	Class 180	
Supplementary Information: Note: See Table 13.1A for Leakage Current Test after Temperature Test						

<b>13.1A</b>	<b>TABLE: Leakage Current – Clause 12.1</b>					<b>P</b>
Points of application	Test voltage (1.06 X rated V)	Freq. (Hz)	Selector Switch Position (ON/ OFF <sup>1</sup> )	Allowed leakage current (mA)	Measured leakage (mA)	
L/N and body	127	50	ON	0,75 mA	0,012 / 0,018 mA	
L/N and body	254	50	ON	0,75 mA	0,006 / 0,010 mA	
Supplementary Information: Note ( <sup>1</sup> ) – Testing with tool in the “OFF” position is required when tool employs a single pole switch and a capacitor						

<b>13.1B</b>	<b>TABLE: Leakage Current – Clause 12.6 d)</b>					<b>N/A</b>
Points of application	Test voltage (1.06 X rated V)	Freq. (Hz)	Selector Switch Position (ON /OFF <sup>1</sup> )	Allowed leakage current (mA)	Measured leakage (mA)	
Supplementary Information: Note ( <sup>1</sup> ) – Testing with tool in the “OFF” position is required when tool employs a single pole switch and a capacitor						

<b>13.1C</b>	<b>TABLE: Leakage Current – Clause 12.6 f)</b>					<b>N/A</b>
Points of application	Test voltage (1.06 X rated V)	Freq. (Hz)	Selector Switch Position (ON / OFF <sup>1</sup> )	Allowed leakage current (mA)	Measured leakage (mA)	
Supplementary Information: Note ( <sup>1</sup> ) – Testing with tool in the “OFF” position is required when tool employs a single pole switch and a capacitor						

<b>13.1D</b>	<b>TABLE: Leakage Current – Clause 14.3</b>					<b>P</b>
Points of application	Test voltage (V)	Freq. (Hz)	Selector Switch Position (ON / OFF <sup>1</sup> )	Allowed leakage current (mA)	Measured leakage (mA)	
L/N and body	120	50	ON	0,75	0,016 / 0,026	
L/N and body	240	50	ON	0,75	0,011 / 0,019	
Supplementary Information: Note ( <sup>1</sup> ) – Testing with tool in the “OFF” position is required when tool employs a single pole switch and a capacitor						

13.1E	TABLE: Leakage Current – Clauses 14.4, 14.5 and 18.12						P
Points of application	Test voltage (V)	Freq. (Hz)	Selector Switch Position (ON/OFF <sup>1</sup> )	Allowed leakage current <sup>2</sup> (mA)	Measured leakage current (mA)	Mode <sup>3</sup> , test condition <sup>4</sup> and/or additional Comments	
L/N and body	127	50	ON	0,75	0,015/0,023	Clause 14.4(a)	
L/N and body	254	50	ON	0,75	0,009/0,016	Clause 14.4(a)	
L/N and body	127	50	ON	5	0,017/0,031	Clause 14.4(b)	
L/N and body	254	50	ON	5	0,012/0,018	Clause 14.4(b)	
L/N and body	127	50	ON	0,75	0,015/0,022	Clause 14.5(a)	
L/N and body	254	50	ON	0,75	0,008/0,015	Clause 14.5(a)	
L/N and body	127	50	ON	5	0,019/0,029	Clause 14.5(b)	
L/N and body	254	50	ON	5	0,011/0,018	Clause 14.5(b)	
L/N and body	120	50	ON	2	0,300	Clause 18.12	
L/N and body	240	50	ON	2	0,290	Clause 18.12	

Supplementary Information:

Note <sup>(1)</sup> – Testing with tool in the “OFF” position is required when tool employs a single pole switch and a capacitor

Note <sup>(2)</sup> – 2 mA for a class II tool, 5 mA for a class I tool

Note <sup>(3)</sup> – Applicable mode, see Clause 14.4

Note <sup>(4)</sup> – Test condition such as 1.0 % NaCl solution at specified pressure for 1 h (Clause 14.5), disable residual current device (Cause 14.5), measurement after tool allowed to dry for 24 h at room temperature, etc.

15.2A	TABLE: Electric Strength Test – Applied after Clause 12.6 d) and 12.6 f)			N/A
Test voltage applied between:	Class of tool	Test voltage (V)	Results after Clause 12.6 d)	Results after Clause 12.6 f)
Between live parts and accessible parts separated from live parts by basic insulation only	Class III	500		
	Other tools	1250		
Between live parts and accessible parts separated from live parts by reinforced insulation	Class II and II Builds	3750		
	Other tools	3750		
For parts with double insulation, between metal parts separated from live parts by basic insulation only, and live parts	Class II and II Builds	1250		
	Other tools	1250		
For parts with double insulation, between metal parts separated from live parts by basic insulation only, and accessible parts	Class II and II Builds	2500		
	Other tools	2500		
Between metal enclosures or covers lined with insulating material and metal foil in contact with the inner surface of the lining	Class II and II Builds	2500		
	Other tools	1250		
Between metal foil in contact with handles and the like and their shafts	Class II and II Builds	2500		
	Other tools	2500		
Between accessible parts and internal diameter of cord guard wrapped with metal foil	Class II and II Builds	2500		
	Other tools	1250		
Between winding/capacitor connection and accessible parts	Class II and II Builds	2U + 1000		
Between winding/capacitor connection and metal parts separated from live parts by basic insulation only	Other tools	2U + 1000		
Supplementary Information:				

15.2B	TABLE: Electric Strength Test – Applied after Clause 14.1.2 and 14.2				N/A
Test voltage applied between:	Class of tool	Test voltage (V)	Results after Clause 14.1.2	Results after Clause 14.2	
Between live parts and accessible parts separated from live parts by basic insulation only	Class III	500			
	Other tools	1250			
Between live parts and accessible parts separated from live parts by reinforced insulation	Class II and II Builds	3750			
	Other tools	3750			
For parts with double insulation, between metal parts separated from live parts by basic insulation only, and live parts	Class II and II Builds	1250			
	Other tools	1250			
For parts with double insulation, between metal parts separated from live parts by basic insulation only, and accessible parts	Class II and II Builds	2500			
	Other tools	2500			
Between metal enclosures or covers lined with insulating material and metal foil in contact with the inner surface of the lining	Class II and II Builds	2500			
	Other tools	1250			
Between metal foil in contact with handles and the like and their shafts	Class II and II Builds	2500			
	Other tools	2500			
Between accessible parts and internal diameter of cord guard wrapped with metal foil	Class II and II Builds	2500			
	Other tools	1250			
Between winding/capacitor connection and accessible parts	Class II and II Builds	2U + 1000			
Between winding/capacitor connection and metal parts separated from live parts by basic insulation only	Other tools	2U + 1000			
Supplementary Information:					



15.2C	TABLE: Electric Strength Test – Applied after Clause 17.2			P
Test voltage applied between:	Class of tool	Test voltage (V)	Results	
Between live parts and accessible parts separated from live parts by basic insulation only	Class III	375	N/A	
	Other tools	937.5	N/A	
Between live parts and accessible parts separated from live parts by reinforced insulation	Class II and II Builds	2812.5	P	
	Other tools	2812.5	N/A	
For parts with double insulation, between metal parts separated from live parts by basic insulation only, and live parts	Class II and II Builds	937.5	P	
	Other tools	937.5	N/A	
For parts with double insulation, between metal parts separated from live parts by basic insulation only, and accessible parts	Class II and II Builds	1875	P	
	Other tools	1875	N/A	
Between metal enclosures or covers lined with insulating material and metal foil in contact with the inner surface of the lining	Class II and II Builds	1875	N/A	
	Other tools	937.5	N/A	
Between metal foil in contact with handles and the like and their shafts	Class II and II Builds	1875	N/A	
	Other tools	1875	N/A	
Between accessible parts and internal diameter of cord guard wrapped with metal foil	Class II and II Builds	1875	N/A	
	Other tools	937.5	N/A	
Between winding/capacitor connection and accessible parts	Class II and II Builds	$(2U+1000) * 0.75$	N/A	
Between winding/capacitor connection and metal parts separated from live parts by basic insulation only	Other tools	$(2U+1000) * 0.75$	N/A	
Supplementary Information:				

15.2D	TABLE: Electric Strength Test – Applied after Clause 17.3			N/A
Test voltage applied between:	Class of tool	Test voltage (V)	Results	
Between live parts and accessible parts separated from live parts by basic insulation only	Class III	500		
	Other tools	1250		
Between live parts and accessible parts separated from live parts by reinforced insulation	Class II and II Builds	3750		
	Other tools	3750		
For parts with double insulation, between metal parts separated from live parts by basic insulation only, and live parts	Class II and II Builds	1250		
	Other tools	1250		
For parts with double insulation, between metal parts separated from live parts by basic insulation only, and accessible parts	Class II and II Builds	2500		
	Other tools	2500		
Between metal enclosures or covers lined with insulating material and metal foil in contact with the inner surface of the lining	Class II and II Builds	2500		
	Other tools	1250		
Between metal foil in contact with handles and the like and their shafts	Class II and II Builds	2500		
	Other tools	2500		
Between accessible parts and internal diameter of cord guard wrapped with metal foil	Class II and II Builds	2500		
	Other tools	1250		
Between winding/capacitor connection and accessible parts	Class II and II Builds	2U + 1000		
Between winding/capacitor connection and metal parts separated from live parts by basic insulation only	Other tools	2U + 1000		
Supplementary Information:				

15.2E	TABLE: Electric Strength Test – Applied after Clause 20.2, 20.3 and 20.4					P
Test voltage applied between:	Class of tool	Test voltage (V)	Results after 20.2	Results after 20.3	Results after 20.4	
Between live parts and accessible parts separated from live parts by basic insulation only	Class III	500	N/A	N/A	N/A	
	Other tools	1250	N/A	N/A	N/A	
Between live parts and accessible parts separated from live parts by reinforced insulation	Class II and II Builds	3750	P	P	P	
	Other tools	3750	N/A	N/A	N/A	
For parts with double insulation, between metal parts separated from live parts by basic insulation only, and live parts	Class II and II Builds	1250	P	P	P	
	Other tools	1250	N/A	N/A	N/A	
For parts with double insulation, between metal parts separated from live parts by basic insulation only, and accessible parts	Class II and II Builds	2500	P	P	P	
	Other tools	2500	N/A	N/A	N/A	
Between metal enclosures or covers lined with insulating material and metal foil in contact with the inner surface of the lining	Class II and II Builds	2500	N/A	N/A	N/A	
	Other tools	1250	N/A	N/A	N/A	
Between metal foil in contact with handles and the like and their shafts	Class II and II Builds	2500	N/A	N/A	N/A	
	Other tools	2500	N/A	N/A	N/A	
Between accessible parts and internal diameter of cord guard wrapped with metal foil	Class II and II Builds	2500	N/A	N/A	N/A	
	Other tools	1250	N/A	N/A	N/A	
Between winding/capacitor connection and accessible parts	Class II and II Builds	2U + 1000	N/A	N/A	N/A	
Between winding/capacitor connection and metal parts separated from live parts by basic insulation only	Other tools	2U + 1000	N/A	N/A	N/A	
Supplementary Information:						

<b>16.1</b>	<b>TABLE: Overload Protection of Transformers and Associated Circuits</b>	N/A
Supplementary Information:		

<b>18.10.2</b>	<b>TABLE: Fault Condition Tests</b>	P			
Ambient temperature (°C)..... :		—			
Component	Fault Condition	Test Voltage (V)	Test Duration	Fuse-link Current (A)	Comment/Result
Control module	Short-circuit	120	30s	-	No operation
Control module	Open-circuit	120	30s	-	No operation
Control module	Short-circuit	240	30s	-	No operation
Control module	Open-circuit	240	30s	-	No operation
Supplementary Information:					

<b>23.1</b>	<b>TABLE: List of Critical Components</b>	P			
Object/Part No.	Manufacturer/ Trademark	Type/Model	Technical Data	Standard	Mark(s) of Conformity <sup>1)</sup>
Supply cord*	Ta An Electric	H05VV-F	3 G 1,5 mm <sup>2</sup>	IEC 60227	VDE
Alternative	Lu Chiang Electric	H05VV-F	3 G 1,5 mm <sup>2</sup>	IEC 60227	VDE
Alternative	I-Sheng Electric	H05VV-F	3 G 1,5 mm <sup>2</sup>	IEC 60227	VDE
Alternative	I-Sheng Electric	H05VV-F	3 G 2,5 mm <sup>2</sup>	IEC 60227	VDE
Alternative	Nexans	H07RN-F	3 G 1,5 mm <sup>2</sup>	IEC 60245	LCIE
Alternative	Nexans	H07RN-F	3 G 2,5 mm <sup>2</sup>	IEC 60245	LCIE
Alternative	Ta Tun Electric	H07RN-F	3 G 1,5 mm <sup>2</sup>	IEC 60245	VDE
Supply cord only for 220-240V*	Ta An Electric	H05VV-F	3 G 1.0 mm <sup>2</sup>	IEC 60227	VDE
Alternative	Lu Chiang Electric	H05VV-F	3 G 1.0 mm <sup>2</sup>	IEC 60227	VDE
Alternative	I-Sheng Electric	H05VV-F	3 G 1.0 mm <sup>2</sup>	IEC 60227	VDE
Alternative	Nexans	H07RN-F	3 G 1.0 mm <sup>2</sup>	IEC 60245	LCIE
Alternative	Ta Tun Electric	H07RN-F	3 G 1.0 mm <sup>2</sup>	IEC 60245	VDE
Power plug*	Ta An Electrical	TP-52	16 A; 250 Vac	IEC 60884	VDE
Alternative	Ta An Electrical	TP-50	16 A; 250 Vac	IEC 60884	VDE
Alternative	Ta An Electrical	TP-51	16 A; 250 Vac	IEC 60884	VDE

Alternative	Ching Cheng Wire Material	EL-208	16 A; 250 Vac	SANS 164-1 SABS 164-1	SABS
Power plug only for 220-240 V*	Ta An Electrical	TP-34	10 A; 250 Vac	BS 1363	IRAM
Alternative	Ta An Electrical	TP-66	250 Vac; 13 A fuse included	BS 1363	ASTA
Alternative	Ta An Electrical	TP-22	10 or 15 A; 250 Vac	IEC 60884	SAA
Alternative	Ta An Electrical	TP-33	10 A; 250 Vac	CEI 23-50	IMQ
Alternative	Ta An Electrical	TP-32	10 A; 250 Vac	IEC 60884	SEMKO
Alternative	Ta An Electrical	TP-23	10 A; 250 Vac	IEC 60884	DEMKO
Power plug only for 110-120 V*	Ningbo Zhpon	P1134	16 A; 130 Vac	IEC 60309	SEMKO
Main switch	Defond Components	BGV-2122-000-R30	250 Vac; 10(10) A 125 Vac; 22(22) A; 5E4	IEC 61058-1	UL/DEMKO
PCB	HANSONIC	FR-4-86	1,6 mm (UL/E131242)	IEC 60745	Tested in Appliance
PRCD	Wenzhou Bestfun	RCD05	220-240 Vac; 16 A; 10 mA; IP55	IEC 61540	TUV
<p>1) An asterisk indicates a mark which assures the agreed level of surveillance  *) or other certified plugs or cables with the same technical data  **) or any other certified brand/type with equivalent ratings and the same construction.</p>					

28.1	TABLE: Clearance and Creepage Distance Measurements						P
Clearance cl and Creepage Distance (dcr) Between:	Up (V)	U r.m.s. (V)	Required cl (mm)	cl (mm)	Required dcr (mm)	Dcr (mm)	
L and N	-	240	2,5	3,2	3,0	>6	
Stator winding and core	-	240	2,0	2,6	2,0	2,6	
Rotor winding and core	-	240	2,0	2,7	2,0	2,7	
Internal wire and enclosure	-	240	4,0	6,2	4,0	6,2	
Commutator and bearing	-	240	8,0	9,3	8,0	>12	
Rotor winding and bearing	-	240	6,0	7,2	6,0	7,2	
Supplementary information: - Creepage and clearance values of Table 10 do not apply to crossover points of motor windings.							

28.2	TABLE: Distance Through Insulation Measurements				P
Distance Through Insulation di Between:	U r.m.s. (V)	Test Voltage (V)	Required di (mm)	Di (mm)	
Metal parts separated by supplementary insulation	240	N/A	1,0	1,5	
Accessible metal parts separated by reinforced insulation	240	N/A	2,0	- <sup>1)</sup>	
Supplementary information: Note <sup>1)</sup> : Live part and accessible part in rotor are insulated by 1,5 mm thickness plastic insulation (Supplementary insulation) and 2 layers thin-sheet (Basic insulation).					

29.1	TABLE: Ball Pressure Test			P
Part under test	Plastic material type	Test Temperature (°C)	Impression Diameter (mm)	
Grip	-	75	1,0	
Brush holder	-	125	1,0	
Support of PCB	-	125	1,2	
Supplementary information:				

29.2	TABLE: Glow Wire Test					P
Test Conditions.....:	Test according to IEC 60695-2-11					—
Test temperature (°C).....:	550°C					—
Test Specimen	Material type	Specified Layer placed underneath Test Specimen	Material ignited, Yes/No	Specified Layer under Test Specimen ignited, Yes/No	Other remarks	
Grip	-	Yes	No	No	P	
Brush holder	-	Yes	No	No	P	
Support of PCB	-	Yes	No	No	P	
Supplementary information:						

<b>29.3A</b>	<b>TABLE: Proof Tracking Test, Annex G</b>				N/A
Test Conditions.....:	Test according to IEC 60112				—
Test solution .....					—
Test Voltage (V).....:					—
Specimen under test	Material type	Tracking occurred, Yes/No	Rate of Tracking	Other remarks	
Supplementary information:					

<b>29.3B</b>	<b>TABLE: Needle-flame Test, Annex F</b>				N/A
Test Conditions.....:	Test according to IEC 60695-2-2				—
Duration of flame application (s) .....					—
Test temperature (°C).....:					—
Specimen under test	Material type	Material ignited, Yes/No	Tissue Paper Ignited, Yes/No	Pine-wood Scorched, Yes/No	Other remarks
Supplementary information:					

<b>K12.1</b>	<b>TABLE: Normal Temperature Test for Battery Tool</b>	N/A
--------------	--	-----

<b>K.18.1</b>	<b>TABLE: Battery Tool Abnormal Operation</b>	N/A
---------------	---	-----

<b>L.18.201</b>	<b>TABLE: Battery Tool Abnormal Operation</b>	N/A
-----------------	---	-----

**Photos**

With D type handle:











With P type handle:







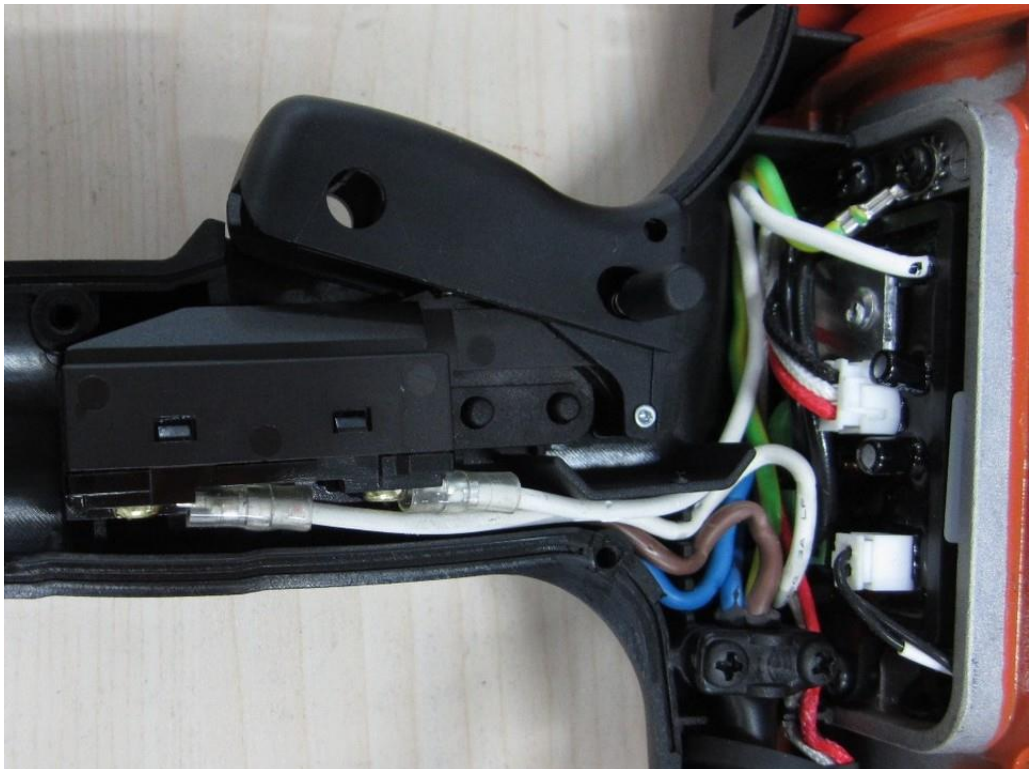
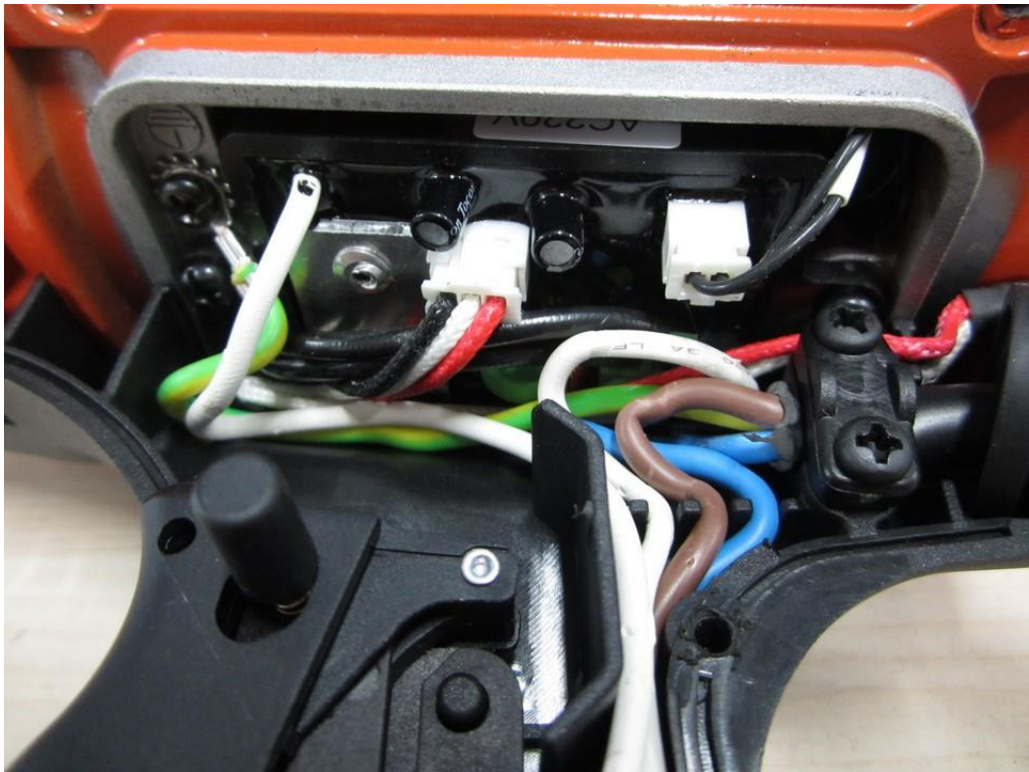

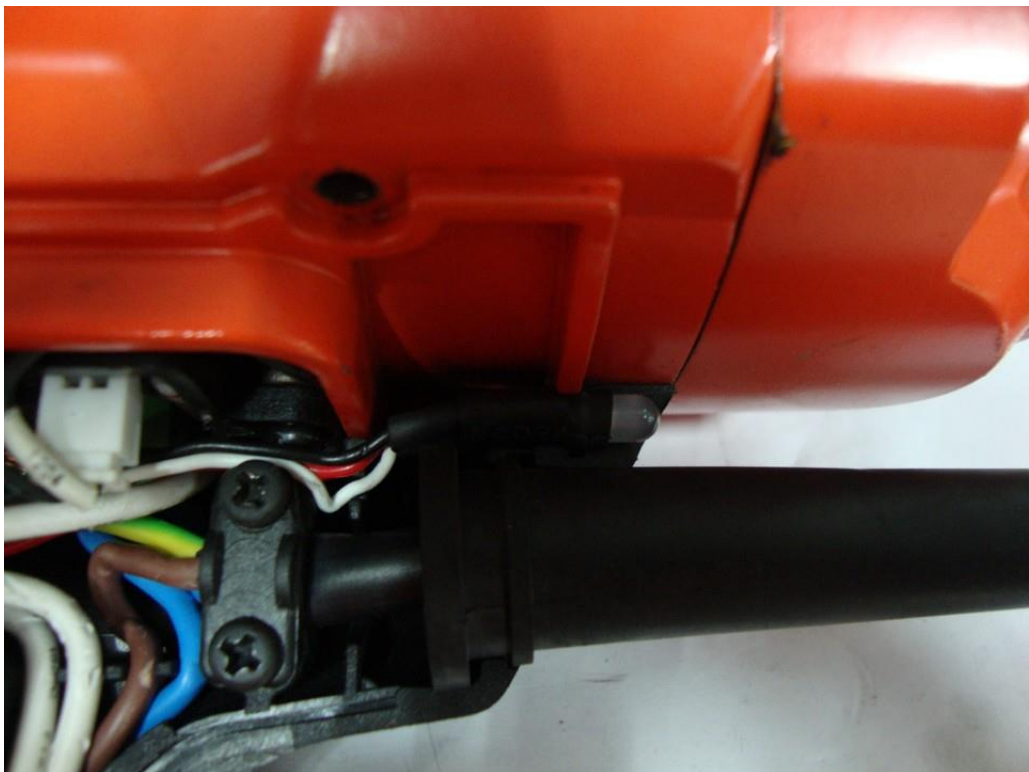
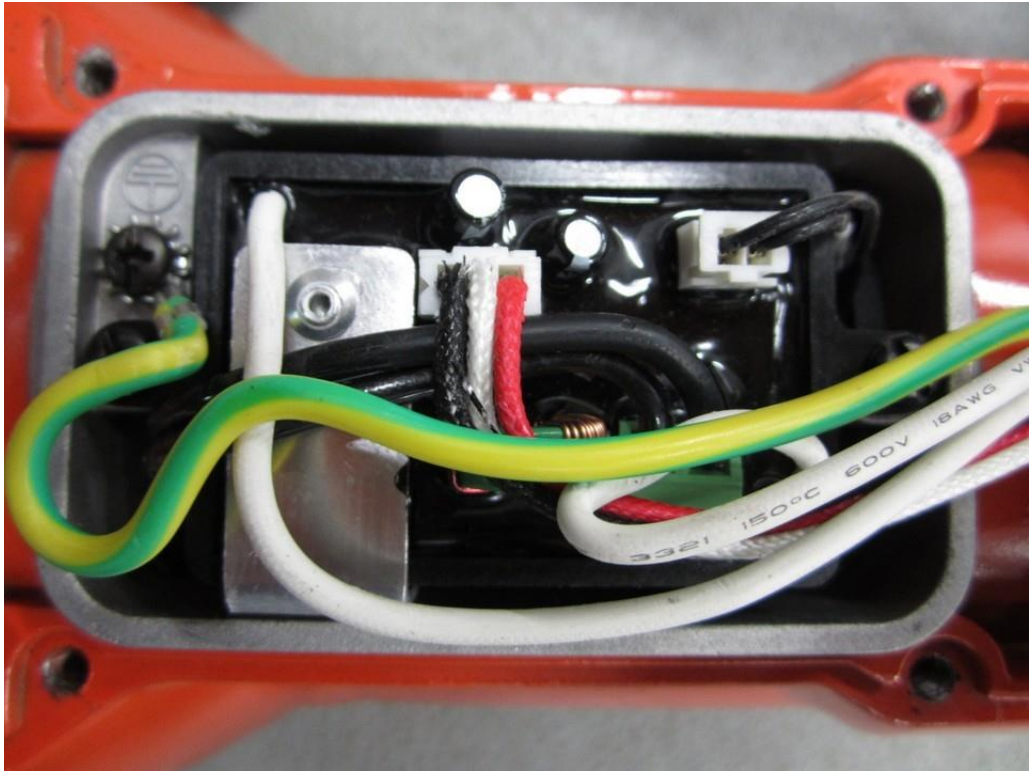



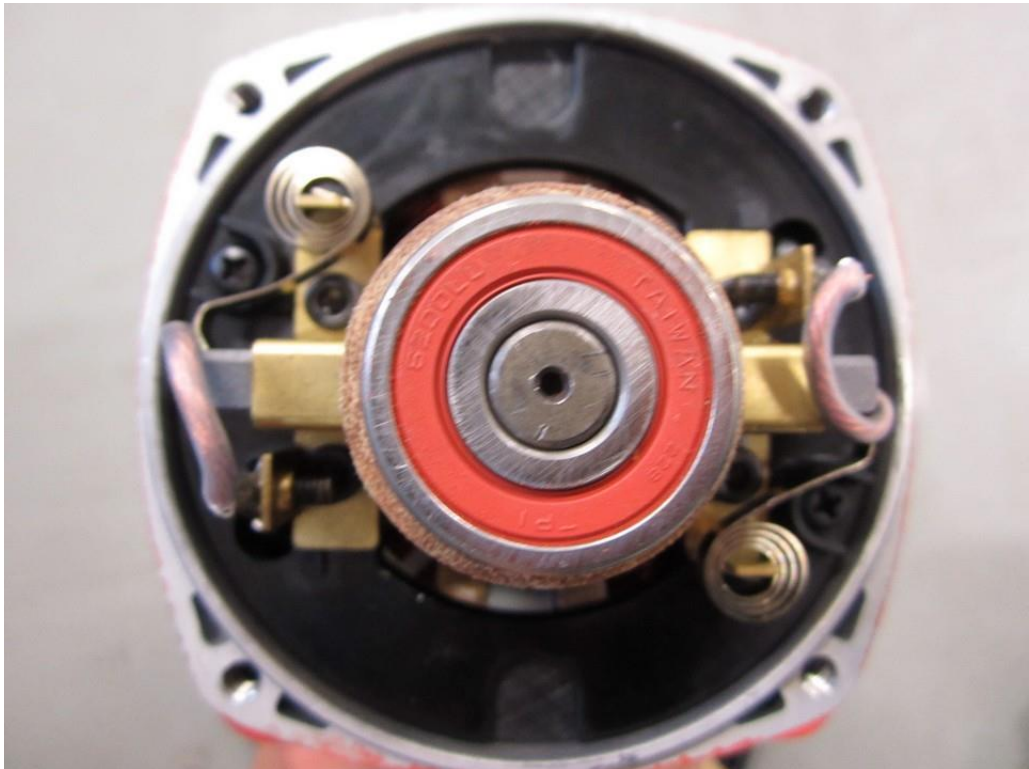

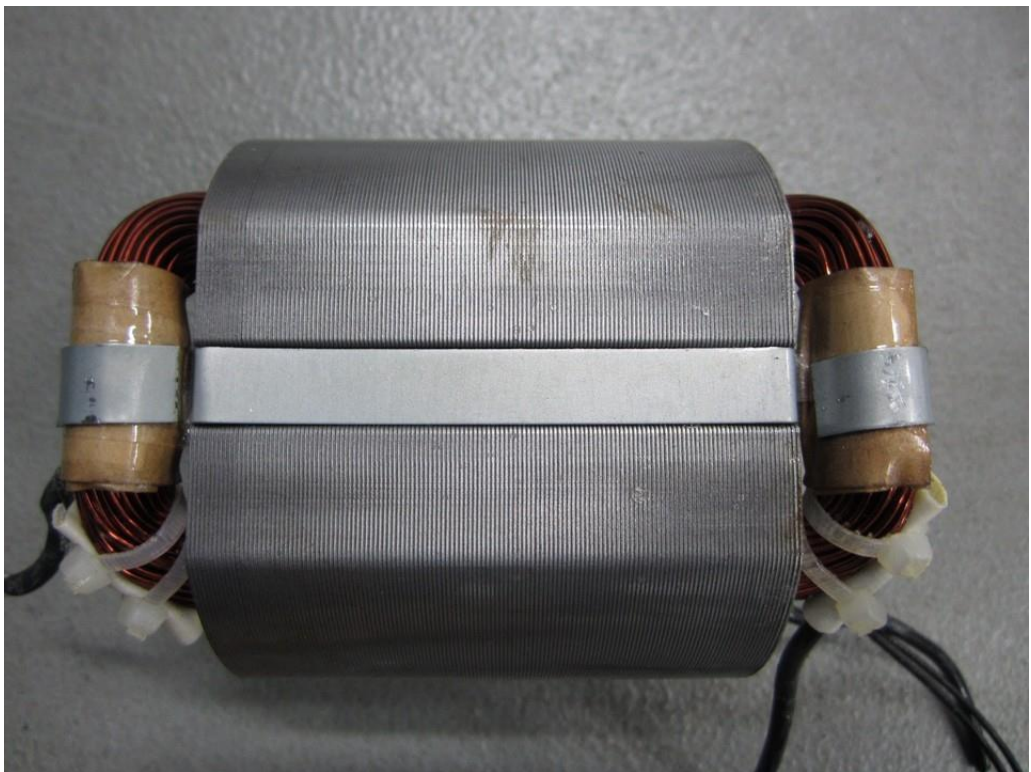
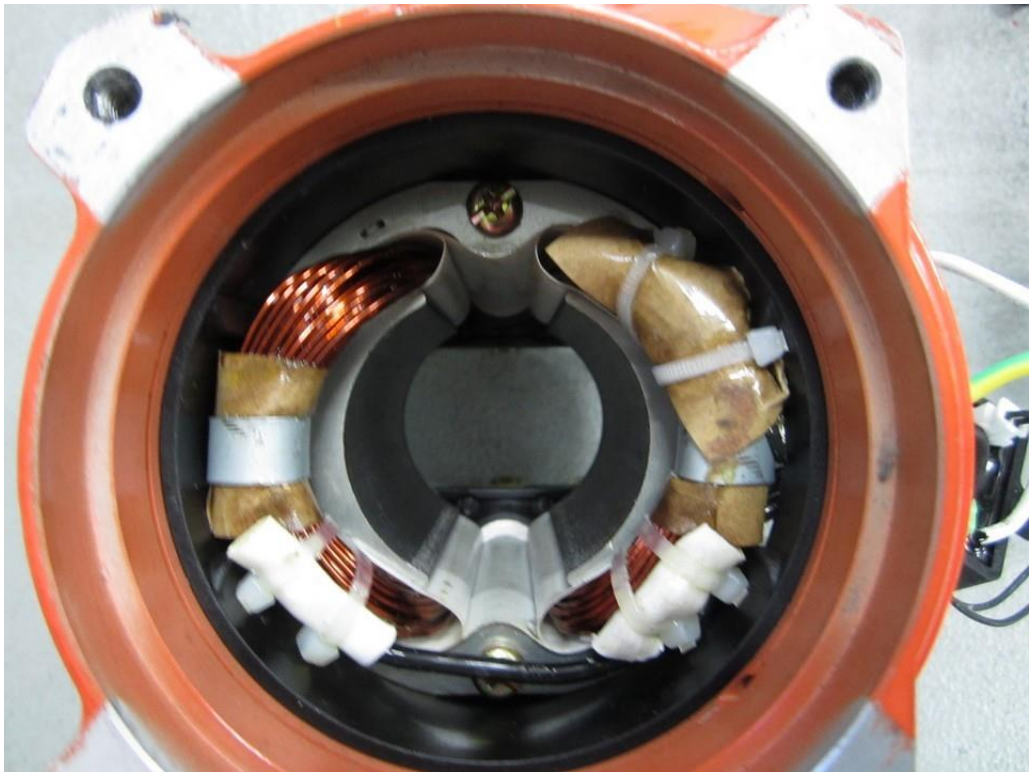

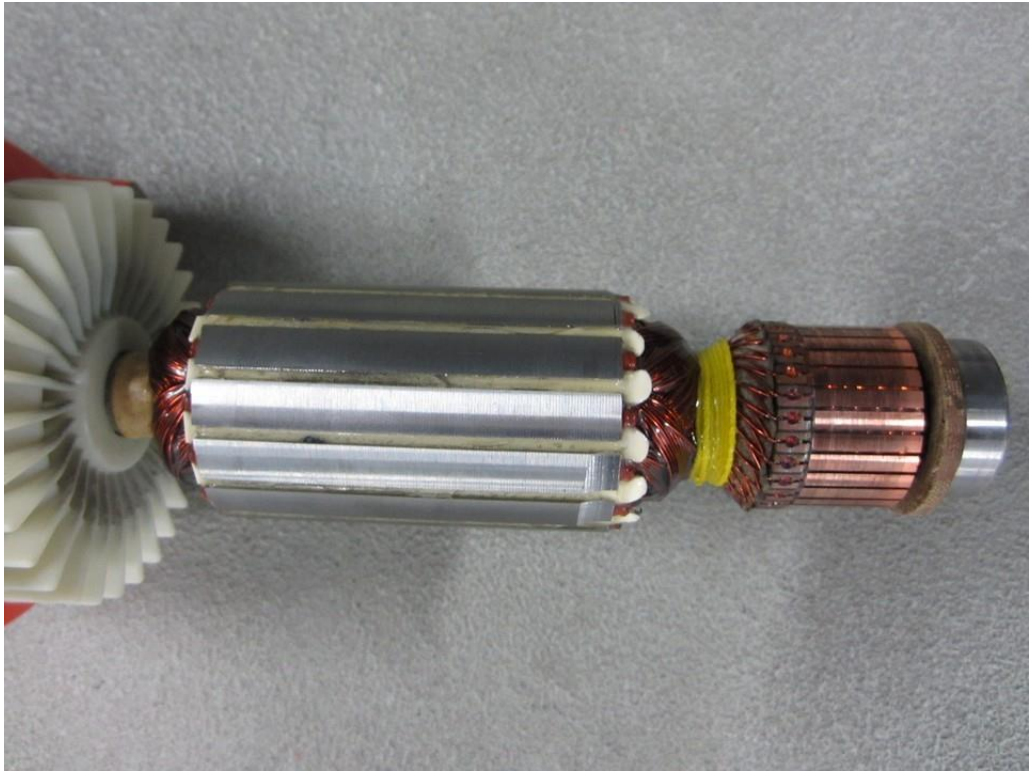



Gear box for DM62; DD62; DD160; EVO20-PDSI; MDB-180P (2 speed):



-----End-----